



CEF/860 | Single-Channel Elimination Filter

Installation and Operation Manual

Please read this manual thoroughly before use.
Keep this manual handy for future reference.

Visit Our Web-Site www.picomacom.com
Contact Us **858.546.5050**
Toll Free **800.421.6511**

Safeguards

Product Inspection

Inspect the equipment for shipping damage. Should any damage be discovered, immediately file a claim with the carrier.

Important Safety Instructions

To ensure proper installation and operation, take a moment to read this guide before proceeding with the installation. If you have any questions or comments about the **CEF/860** Elimination Filter, please contact your dealer or have him contact the **PICO MACOM** Service Center at the phone number on the bottom of the page.



The lightning flash with arrowhead symbol, within an equilateral triangle, is intended to alert the user to the presence of uninsulated “dangerous voltage” within the product’s enclosure that may be of sufficient magnitude to constitute a risk of electric shock to persons.



The exclamation point within an equilateral triangle is intended to alert the user to the presence of important operating and maintenance (servicing) instructions in the literature accompanying the appliance.

WARNING: TO REDUCE THE RISK OF FIRE OR ELECTRIC SHOCK, DO NOT EXPOSE THIS APPLIANCE TO RAIN OR MOISTURE. DO NOT OPEN THE CABINET. REFER SERVICING TO QUALIFIED PERSONNEL ONLY.

CAUTION: TO PREVENT ELECTRIC SHOCK DO NOT USE THIS (POLARIZED) PLUG WITH AN EXTENSION CORD RECEPTACLE OR OTHER OUTLET UNLESS THE BLADES CAN BE FULLY INSERTED TO PREVENT BLADE EXPOSURE.

ATTENCION: POUR PREVENIR LES CHOCES ELECTRIQUES, NE PAS UTILISER CETTE FICHE POLARISEE AVEC UN PROLONGATEUR, UNE PRISE DE COURANT OU UNE AUTRE SORTIE DE COURANT, SAUF SI LES LAMES PEUVENT ETRE INSEREES A FOND SANS EN LAISSER AUCUNE PARTIE A DECOUVERT.

- 1. Read Instructions:** All safety and operating instructions should be read before the appliance is operated.
- 2. Retain Instructions:** The safety and operating instructions should be retained for future reference.
- 3. Heed Warnings:** All warnings on the appliance should be adhered to.
- 4. Follow Instructions:** All operating and user instructions should be followed.
- 5. Cleaning:** Unplug this appliance from the wall outlet before cleaning. Use a damp cloth for cleaning. Do not use liquid cleaners or aerosol cleansers.
- 6. Do Not Use Attachments:** Use of attachments not recommended by the manufacturer may cause hazards.
- 7. Water and Moisture:** Do not use this product near water—for example, near a bathtub, washbowl, kitchen sink, laundry tub, in a wet basement, or near a swimming pool—and the like.
- 8. Accessories:** Do not place this product on an unstable cart, stand, tripod, bracket, or table. The product may fall, causing serious injury to a child or adult, and serious damage to the appliance.
- 9. Ventilation:** This video product should never be placed near or over a radiator or heat register. This video product should not be placed in a built-in installation such as a bookcase or rack unless proper ventilation is provided or the manufacturer’s instructions have been adhered to. Any slots or opening in the cabinet are provided for ventilation. To ensure reliable operation of the video product and to protect it from overheating, these openings must not be blocked or covered. Openings should never be blocked by placing the product on a bed, sofa, rug, or other similar surface.
- 10. Grounding or Polarization:** This video product is equipped with either a three prong plug for 110 VAC use or a two prong flat blade 220 VAC type plug. Each type is to be inserted into only the type of receptacle for which they specifically designed. Do not cut off the round grounding pin in order to be able to fit into a two prong receptacle as this could cause injury and will void the warranty.

11. Power Sources: This product should be operated only from the type of power source indicated on the marking label. If you are not sure of the type of power supplied to your home, consult your appliance dealer or local power company.

12. Power-cord Protection: Power-supply cords should be routed so they are not likely to be walked on or pinched by items placed upon or against them. Pay particular attention to cords and plugs, convenience receptacles, and the point where they exit from the appliance.

13. Lightning: For added protection for this product during a lightning storm, or when it is left unattended or unused for long periods of time, the unit should be disconnected from power source.

14. Power Lines: An outside antenna system should not be located in the vicinity of overhead power lines, other electric light or power circuits, where it can fall into such power lines or circuits. When installing an outside antenna system, extreme care should be taken to keep from touching such power lines or circuits as contact with them may be fatal.

15. Overloading: Do not overload wall outlets and extension cords as this can result in risk of fire or electric shock.

16. Object and Liquid Entry: Never push objects of any kind into this product through openings as they may touch dangerous voltage points or short-out parts that could result in a fire or electric shock. Never spill liquid of any kind on the product.

17. Servicing: Do not attempt to service this product yourself as opening or removing covers may expose you to dangerous voltage or other hazards. Refer all servicing to qualified service personnel.

18. Damage Requiring Service: Unplug this product from the wall outlet and refer servicing to qualified service personnel under the following conditions:

- When the power-supply cord or plug is damaged.
- If liquid has been spilled, or objects have fallen into the product.
- If the product has been exposed to rain or water.
- If the product does not operate normally by following the operating instruction. Adjust only those controls that are covered by the operating instructions. An improper adjustment may result in damage and will often require extensive work by a qualified technician to restore the product to its normal operation.
- If the product has been dropped or the cabinet has been damaged.
- When the product exhibits a distinct change in performance—this indicates a need for service.

EXAMPLE OF ANTENNA GROUNDING ACCORDING TO NATIONAL ELECTRICAL CODE INSTRUCTIONS CONTAINED IN ARTICLE 810 - "RADIO AND TELEVISION EQUIPMENT"

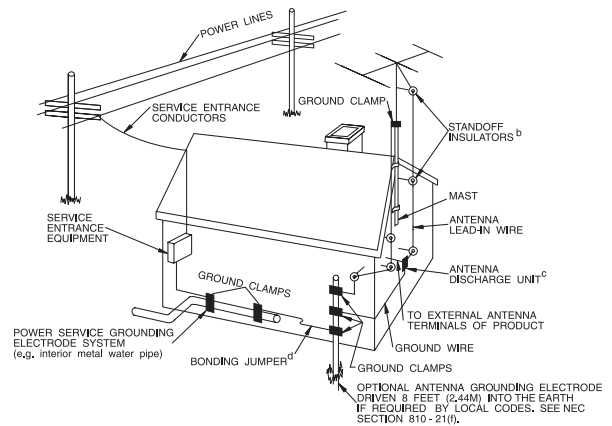

19. Replacement Parts: When replacement parts are required, be sure the service technician has used replacement parts specified by the manufacturer or have the same characteristics as the original parts. Unauthorized substitutes may result in fire, electric shock or other hazards.

20. Safety Check: Upon completion of any service or repairs to this product, ask the service technician to perform safety checks to determine that the product is in proper operating conditions.

21. Outdoor Antenna Grounding: Before attempting to install this product, be sure the antenna or cable system is grounded so as to provide some protection against voltage surges and built-up static charges.

- Use No.10 AWG (5.3mm) copper, No.8 AWG (8.4mm) aluminum, No.7 AWG (10mm) copper-clad steel or bronze wire or larger, as ground wire.
- Secure antenna lead-in and ground wires to house with stand-off insulators spaced from 4 feet (1.22m) to 6 feet (1.83m) apart.
- Mount antenna discharge unit as close as possible to where lead-in enters house.
- A driven rod may be used as the grounding electrode where other types of electrode systems do not exist. Refer to the National Electrical Code, ANSI/NFPA 70-1984 for information.
- Use jumper wire not smaller than No.6 AWG (13.3mm) copper or equivalent, when a separate antenna grounding electrode is used.

NOTE TO THE CATV SYSTEM INSTALLER

THIS REMINDER IS PROVIDED TO CALL THE CATV SYSTEM INSTALLER'S ATTENTION TO ARTICLE 820-22 OF THE NEC THAT PROVIDES GUIDELINES FOR PROPER GROUNDING AND, IN PARTICULAR, SPECIFIES THAT THE CABLE GROUND SHALL BE CONNECTED TO THE GROUNDING SYSTEM OF THE BUILDING, AS CLOSE TO THE POINT OF CABLE ENTRY AS PRACTICAL.



CEF/860

 | Single-Channel Elimination Filter

The Pico Macom **CEF860** is professional grade single channel elimination filters designed to provide a 6MHz-wide carrier-free environment to insert locally originated channels. When used in conjunction with **Pico Macom's** high quality modulators, these units are the most cost-effective method to add locally originated programming to an MATV or CATV system while ensuring the highest quality picture across the band. This unit employs multi-stage cavity bandpass and notch filtering to provide single channel rejection depth typically greater than -55dB, thereby eliminating disruptive carriers and greatly improving picture quality. Also, the unique filter design and sharp frequency cut-off provide minimum adjacent channel disruption and excellent passband frequency response ensuring no degradation in system performance. In systems requiring more than one inserted channel, up to 3-units can be cascaded for multiple channel elimination and reinsertion with negligible interaction. The **CEF860** is pre-tuned to any channel in the notch range for easy drop-in installation. **Pico Macom** backs up this product with its industry leading 5-year limited warranty.

Features

- CEF860 135-Channel Passband 54-860 MHz (CATV 2-135) eliminating any single channel between 54-336 MHz (CATV 2-42)
- Deep -55dB typical cavity-tuned notch filter for clean signal removal of selected cable channels and subsequent insertion of locally originated signals
- High-Q helical resonators with unique coupling circuitry provide excellent long-term stability
- Sharp filter cut-off edges allow adjacent channels to be processed with negligible loss
- Up to 3 units can be cascaded for multiple channel elimination and reinsertion with negligible interaction
- Compact and efficient design enables single rack unit (1³/₄) height installation saving valuable rack space
- Fail-safe installation as input and output may be reversed without effect

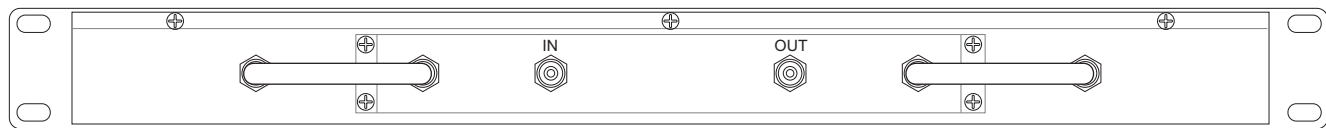

Specifications

Passband Frequency Range:	5 - 860 MHz
Rejection Band Frequency Range:	54 - 336 MHz
Rejection Band Channel Range:	Channel 2 to FF
Rejection Bandwidth:	6 MHz
Channel Rejection (min.):	50 dB
Insertion Loss:	4 dB max. (2.5 dB typ.)
Adjacent Channel Loss:	
Low Band	5.5 dB max. (4 dB typ.)
Mid, High Super, Hyper Band	8.0 dB max. (6 dB typ.)
Impedance:	75 Ohm
Connectors:	"F" female
Dimensions:	19"(L) x 8.5"(D) x 1.75"(H)
Weight:	5.35 lbs.

Ordering Information

CEF/860 -

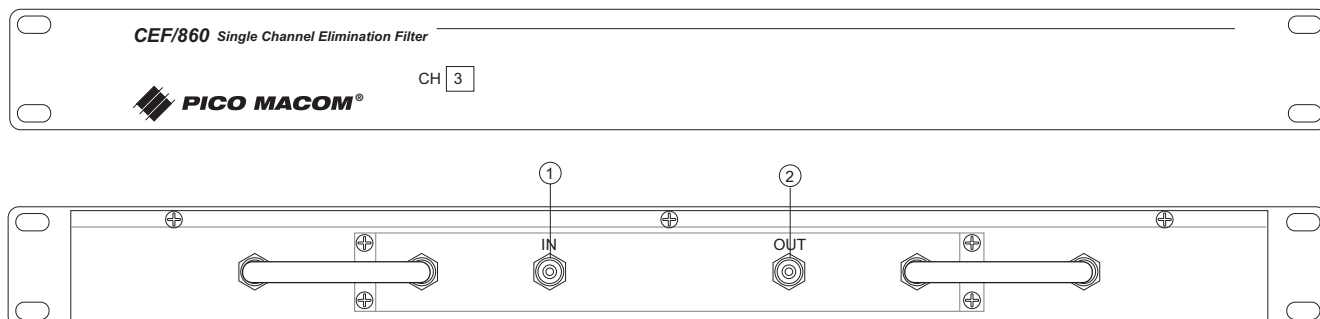

Back Panel Control

- 1. Input:**
The Input RF Signal is connected to this port
- 2. Output:**
The RF signal minus the eliminated channel is available at this port

Installation

It is recommended that assistance be available to safely install equipment in equipment racks.

1. Install **CEF/860** in equipment rack (rack sold separately) by supporting the bottom and rear of the unit at the desired elevation in rack.
2. Line up the mounting holes of the **CEF/860** with the tapped equipment rack holes.
3. Insert the provided screws through the chassis holes and thread into the tapped rack holes.
4. Fasten the bottom screws first, then fasten top screws. Tighten securely.
5. Connect a cable from the antenna or **CATV** signal source to the input of the **CEF/860**. Verify that there are no line voltages present.
6. The output of the **CEF/860** is connected to a headend channel combiner (PHC-12G, PHC-24G or CHC-16U). A signal splitter such as a **TSB-21G** may be used backwards as a combiner.
7. Signal levels must be identical at the “point of insertion”.
8. The cable tv feed signal level is shown only as an example. It may be higher or lower.

Two applications are shown:

1. This configuration is used to relocate channels 24 and 35 to new locations channels 36 and 43.
2. This configuration is used to insert a local signal source into a cable system.

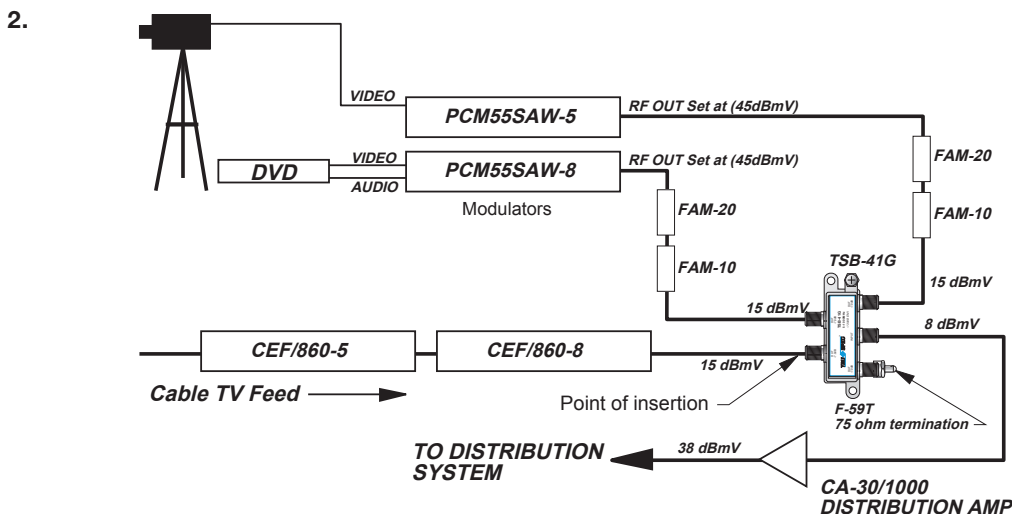
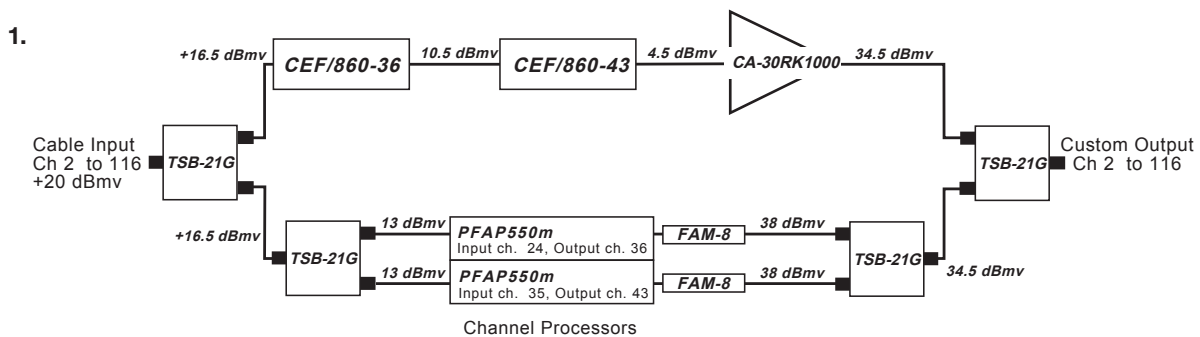

Limited Warranty

Pico Macom warrants to the original purchaser that all of its new products are of sound design, quality materials and workmanship at the time of manufacture and will be free from related defects for one year from the original purchase date. Pico Macom will repair or, at its discretion, replace without cost to the original purchaser, the product which, upon inspection by Pico Macom, appears to be defective or not conforming to factory specifications. Pico Macom will cover the cost of parts, labor, and return freight from factory.



Five-Year Limited Warranty

Most products designated as “Headend Electronics” are further covered by an extended 4-year period beyond the expiration of the original 1-year warranty, for a full 5-year period. Qualified equipment requiring factory repair during the extended 4-year period is covered under our re-certification program. Re-certification fees under this program shall not exceed 20% of the product’s List Price and whenever possible, Pico Macom will attempt to upgrade performance to the latest improved specification.

Warranty Limitations

This warranty excludes coverage of damage or inoperability resulting from (1) use or installation other than in strict accordance with Pico Macom’s written instructions, (2) disassembly or repair by someone other than Pico Macom or a Pico Macom authorized repair center, (3) misuse, misapplication or abuse, (4) alteration, (5) lack of reasonable care or (6) wind, ice, snow, rain, lightning, power surges, excessive heat, or any other weather conditions or acts of God. Pico Macom’s warranty with respect to third-party proprietary sub-assembly modules and/or private-label products are limited to the duration and terms of third-party vendors’ warranty. Pico Macom shall in no event and under no circumstances be liable or responsible for any consequential, indirect, incidental, punitive, direct or special damages based upon breach of warranty, breach of contract, negligence, strict tort liability or otherwise or any other legal theory, arising directly or indirectly from the sale, use, installation or failure of any product acquired by buyer from Pico Macom. This limited warranty extends to the original purchaser. Pico Macom reserves the right to modify or discontinue this warranty at Pico Macom’s sole discretion without notification. No other warranties are expressed or implied.

Damage or Shortage Claims

Our shipping staff carefully packs and ships your orders in compliance with common carriers’ requirements. Please make note of any obvious damage or shortage on the freight bill or carrier’s receipt next to your signature. The carrier’s agent must too sign acknowledging the loss. Failure to do so may result in the carrier’s refusal to honor the claim. Please open your order immediately upon receipt to check for concealed damage and compare the packing list to the items shipped. If damaged, keep the original shipping cartons for possible inspection by the carrier. You must report claims for loss or damage within 3 days of delivery, while claims for erroneous charges or price corrections must be presented within 30 days of invoice date.

Returning Shipped Items

To return any shipped items, including those shipped for warranty repairs or credit, call our Customer Service desk to request a Return Merchandise Authorization (RMA) number. Please reference the original invoice number and purchase date, and product serial number (if any). Be certain to mark the RMA number on the package boldly and legibly. Unless we specify a different carrier, please ship your returned items to us via UPS freight prepaid and fully insured. If returned for credit, we will promptly process your request upon receipt of your return order.

Our Return Policy: Your Satisfaction Guaranteed

Our goal is your complete satisfaction. If for any reason, our products were not quite what you anticipated, simply call your customer service rep and we will be happy to assist you in replacing or returning the order. You may return current, non-discontinued items for full credit for up to 30 days from invoice date. Our requirements are simple: Excepting defective items, the products must be returned in their original packaging and in re-salable condition. Restocking fees may otherwise apply beyond this period or if products are not returned in their original condition. Please contact your customer service rep for more information.