

Product Manual



ICC2-ATSC 4

HDTV Tuner/Controller

June 28, 2016

S12 Control Version 6.2
HD Processor Version 5.09



Table of Contents

Overview	3
Specifications	4
Physical	4
Front Panel	4
Rear Panel	4
Tuning	5
Includes	5
Options	5
Trademarks	5
FAQ	6
RF Wiring Options	7
Setup Guide	8
IR Remote Operation	8
Front Panel Setup	9
RS-232 Control Codes	10
Input Selects	10
Input Command	10
IC-Net Control Protocol	12
Overview	12
Command String Structure	12
IC-Net Commands	13
Control	13
Tuning	14
Tuning	15
Text	15
HD2-RC Remote Emulation	16
IC-Net Response	17
iC-Net Zones, Units and Device Addresses	18
System Map	19
On-Screen Menus	20
Main Menu	20
Channel Menus	20
Caption Menus	21
V-Chip Settings Menus	21
Setup Menus	22
Safety Instructions	24
Limited Warranty and Disclaimer	24

Overview



The ICC2-ATSC 4 HDTV Tuner includes all the proven performance of the previous ICC2-ATSC+, plus added features from the 232-ATSC 4 tuner.

- Receives MPEG4 and MPEG2 programs
- Outputs up to 1080p video

The ICC2-ATSC 4 HDTV Tuner is an integrated HDTV tuner/controller that networks HD display monitors and projectors in a Display Express control system. As a universal TV tuner, the ICC2-ATSC 4 can receive ATSC, NTSC, and clear QAM cable channels from an MATV antenna or CATV cable RF system.

The tuner displays broadcasts through simultaneous HDMI and NTSC composite ports and switched HD RGBHV or Component outputs. Full-time audio is available from digital Dolby 5.1/PCM/Variable PCM HDMI, optical, and coax ports, as well as variable-level analog stereo audio outputs.

- **Integrated Display Control** - Employs RS-232 control port for integrated display or video projector control, includes onboard database of display control command
- **Through-the-RF Coax Networking** - Communicates with Display Express Web software, and custom control systems via iC-Net RF protocol
- **Universal Tuning** – Handles a mix of ATSC, clear QAM (MPEG and MPEG4) and NTSC channels, cable or off-air tuning
- **Pro Integration** - Features 2-way RS-232 control and feedback with simple ASCII commands, as well as discrete IR and wired IR - AMX and Crestron modules available
- **Fast Tuning** - Changes analog and digital channels instantly with improved RF reception
- **Total Video** - Simultaneous HDMI and composite video, switchable RGBHV or Component HD video
- **Total Audio** - Simultaneous digital Dolby 5.1/PCM/Variable PCM HDMI, coax, and optical outputs, as well as variable-level analog stereo
- **HD Scaling** - Upscales HD output up to 1080p
- **Easy Set-up** - Front-panel programming supported by LCD display, on-screen menus using HD2-RC IR remote (included), and RS-232 control commands
- **Closed Captioning** - Displays analog and digital captioning text
- **On-Screen Menus** - Setup, Electronic Program Guide, Channel, Favorites, and Program Information menus
- **Compact Rack Mounting** - Mounts in 2RU single RK1-HD or dual RK2-HD 19" rack kits
- **Includes** - 12 VDC switching power supply
- **Options** – HD2-RC wireless remote, RK1-HD and RK2-HD rack kits, CC-232 or CC-COM RS-232 control cables, IR-RXC External IR Receiver
- **Green Machine** - Meets RoHS safety and California energy standards
- **Field Updatable** – download new control and HD processor firmware from CR website

Specifications

Physical

- Size (HWD):** 8.5" [216mm] wide x 2.0" [51mm] height (1.5 RU) x 8.0" [203mm] deep
- Weight:** 1.94 lbs [890 g]
- Enclosure:** Steel with black powder coat paint
- Mounting:** 2/1.5RU Rack mounting for one or two units side-by-side optional (RK1/2-HD+, RK1S/RK2S-HD+)

Front Panel

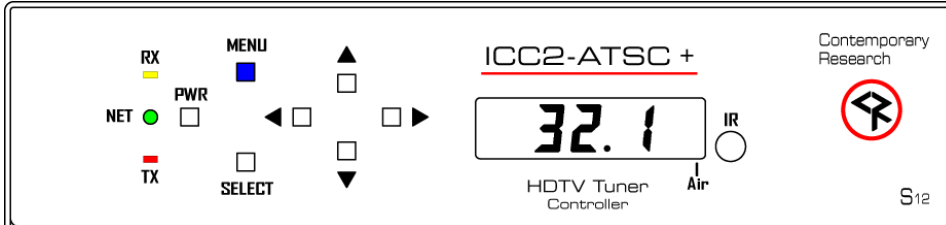

- Display:** Red LED Channel Display, dot separated major and minor channel numbers, dot at end indicates Off-Air tuning
- IR:** IR sensor
- Control:** Power, Menu, and Select buttons, navigation using Up and Down (Channel Up and Down) buttons Left and Right (Volume Down and Up) buttons
- LEDs:** RS-232 RX (Yellow), RS-232 TX (Red), Net (Green – flashes every second to confirm iC-Net control signal)

Rear Panel

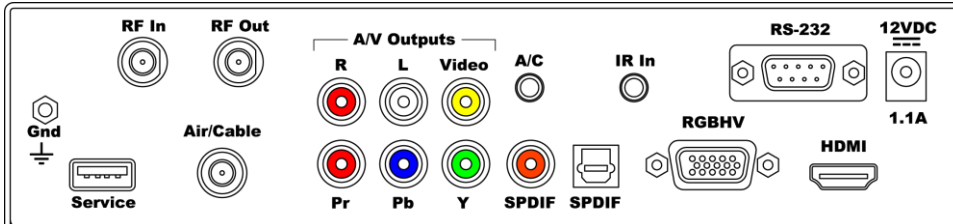

- Service:** USB port (not active presently)
- RF In:** Air/Cable, 'F', female, 75 ohm impedance, -10 to 15 dBmV typical, receives RF control channel
- RF Out:** 'F', female, Passes RF channels to Air/Cable input, cable included
- Air/Cable:** 'F', female, 75 ohm impedance, -10 to 15 dBmV typical
- A/C Jack:** 3.5mm jack for RF-AB Air/Cable Switch
- Video Output:** Simultaneous HDM and NTSC video, switch between RGB and Component
 - Video Out:** RCA composite video output, 1V p-p at 75 ohm impedance, 480i
 - Component Out:** 3 RCA Y, Pr, Pb outputs (1080p/1080i/720p/480p/480i)
 - RGB Out:** RGBHV DB-15 female (1080p/1080i/720p/480p, 59.95 Hz)
 - HDMI:** HDMI receptacle, Type A, HD video and digital audio, version 1.3 (1080p/1080i/720p/480p)
Use PCM mode if HDMI audio connection is used to most displays (not all have Dolby)
- Audio Output:** Simultaneous HDMI, Coax, Optical, and Stereo
 - Digital Audio SPDIF:** Coax and Toslink optical output, Dolby 5.1 AC3/PCM/Variable PCM
 - Analog Audio Out:** Stereo RCA audio, Mono, Stereo, or SAP, variable level
- RS-232 Control:** DB-9 male, RS-232 data link to control system or PC, up to 9 tuners, 300-19,200 baud
- IR In:** 3.5mm stereo jack for optional IR-RXC IR Receiver
 - Sleeve= DC power+ from power jack input, limited to less than 100mA
 - Ring=DC power- (GND)
 - Tip= IR data signal
- Power In:** 2.1mm coaxial jack (inside center conductor positive)
1.1 A maximum, 11.5 to 15 VDC, 12 VDC typical

Tuning

Frequency Range: ATSC and Clear QAM (cable) television 55.25 to 801.25 MHz

TV System: ATSC, NTSC, Cable, and Clear QAM (1080i/720p/480p/480i)

Tuning: Off-air 14-69 (NTSC and 8-VSB) and CATV 1-135 (Analog, 64QAM, 256QAM, 8-VSB)

Aspect Ratio: 4:3, 16:9 (Digital), 4:3, 16:9, Zoom (Analog channels)

Captioning: DTV and analog, set by program or customized for size, font and display attributes

Captioning Data: HDMI, RGB, and Component ports don't have the ability to carry captioning data.

The composite video port will carry Line 21 data, but only when tuned to an analog channel

Lock: Parental option for channels and/or rating

Includes

Compact Power Supply, 1.5A maximum, 12 VDC

RF Loop Cable for connection of RF Out to Air/Cable input

Options

RK1-HD+ Single Rack Kit, 2RU

RK2-HD+ Dual Rack Kit, 2RU

RK1S-HD+ Single Space-Saver Rack, 1.5RU (reverse mount to stack)

RK2S-HD+ Dual Space-Saver Rack, 1.5RU (reverse mount to stack)

PMT-2+ Pole Mount Bracket

RF-AB RF A-B Switch, self-terminating, closure controlled (if system has dual Air and Cable feeds)

IR-RXC External IR Receiver

CC-COM or CC-232 RS-232 Control Cable

Firmware

HD V3.05 Provides Line captioning data on Composite video from analog and digital channels, tuner stays on sub-channel with program data is lost, does not change to default N.1 channel.

SF V5.1 This adapts commands to operate with a new series tuner board.

Trademarks

- VGA and XGA are trademarks of International Business Machines
- SVGA is a trademark of the Video Electronics Standard Association
- HDMI, the HDMI logo and High-Definition Multimedia Interface are trademarks or registered trademarks of HDMI Licensing LLC.



Manufactured under license from Dolby Laboratories, Dolby and the double-D symbol are trademarks of Laboratories

FAQ

Tuning Cable Channels	The 232-ATSC 4 will skip encrypted channels automatically when you activate a channel scan. You can skip scanning analog channels by pressing Select after you start the scan. Typically, the digital channels will not use the same Guide numbers as a cable box. If you can't select channels, make sure that the channels have been scanned.
RGB/Component Video	Analog HD is output on either the RGBHV (VGA) or Component output. Use the front-panel menu to select the desired output. There can be "fluttery" lines at the top of the analog video – this is closed captioning data. Go to the Overscan menu and increase the value.
HDMI	HDCP is always off – not required for non-encrypted programs If a monitor has issues with current resolution, 1080p/60 works best for newer models.
DVI	DVI conversion is normally supported; you can manually select DVI from the HDMI-DVI menu.
Composite Video	Press the RATIO button on the IR remote to select the desired format for NTSC video The onscreen menu also has Screen Format settings, generally only used when tuning an analog channel
Audio	Volume won't affect digital audio in AC-3 or PCM modes PCM Variable supports level control If there is no audio, make sure the volume is all the way up (and not muted). Digital audio is sent as Consumer format, the Digital Audio menu can change to Professional format A "motorboat" sound means the source does not support AC-3, change to PCM.
Power/AV	If the LCD shows only Power On, call CR Support for solutions If you can't change volume or channels and there is no video, first try an alternate power supply, call Support if needed. The tuner will display "Voltage Low" if the power supply is failing or low. Press SETUP, go to the Firmware menu, and then press the Right arrow several times to see the exact voltage. There is a "Voltage High" warning if the supply is significantly higher than 12 VDC.
IR Control	There can be interference from room fluorescent lights. Hold down SELECT on the remote. Pressing 4 selects normal 38 KHz IR, pressing 9 selects 57 KHz IR. Check the front-panel IR Receive menu to see if it is turned on or off. If there is significant IR interference, an IR-RXC Remote Sensor may be required, and cover the front-panel IR sensor to reduce interference
Captioning	If the tuner is feeding a digital channel modulator, use Composite video to send captioning data. If the site wants to see captioning on all TVs, turn the feature on in the tuner.

RF Wiring Options

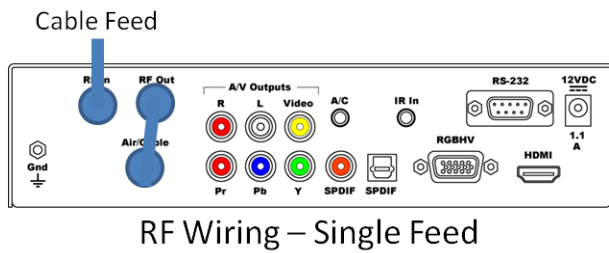

RF Wiring – Single Feed

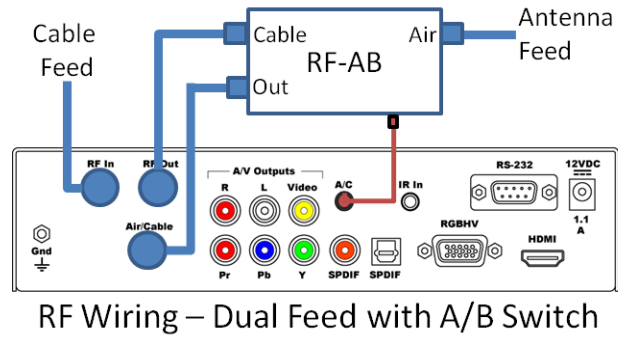

RF Wiring – Dual Feed with A/B Switch

There are two ways to wire RF feeds to the ICC2-ATSC+.

Single RF Feed

Most applications will use a single RF feed, either Cable or Air (Antenna).

- Connect the RF feed to RF In on the top of the tuner. This allows the tuner to receive the iC-Net control signal.
- Connect the included short RF cable from RF Out to the Air/Cable RF input. A low-loss tap feeds the RF feed the ATSC+ tuner.

Dual RF Feed

Other applications will use both Cable and Air (Antenna) feeds. The ICC2-ATSC 4 can switch between both, maintaining separate channels lists for each. You'll need the optional RF-AB switch, which has a mini 3.5mm cable that connects to the A/C control output on the back of the tuner. The placement of RF connections on the RF-AB is different than shown – the RF ports above are arranged for clarity.

- Wire the Cable feed to the RF input of the ATSC+. Note that the Cable feed needs to go through the RF In on the ATSC+ first, so the tuner can receive the iC-Net control channel.
- Connect the ATSC+ RF Out to the Cable input of the RF-AB.
- Connect the Air/Antenna feed to the Air input of the RF-AB.
- Connect the included short RF cable to the RF-AB switch RF Out, then to the Air/Cable RF input on the ATSC+.
- Connect the 3.5mm mini plug to the ATSC+ A/C control output.

Setup Guide

The ICC2-ATSC 4 supports a mix of setup tools, including:

- HD2-RC Remote Mode (accesses On-Screen Graphic Menus and special HD functions)
- IC-RC Remote Mode (accesses Text Menus and special media functions)
- Front-Panel Setup
- IC-Net commands from system or iC Send

The reason for the options is that the ICC2-ATSC 4 is designed to offer advanced analog/digital tuning, yet be compatible with existing iC-Net systems.

IR Remote Operation

The IC-RC Remote is used with analog tuners as well as media and text menu control functions when used in iC-Net control systems. The HD2-RC IR Remote is designed for control and setup of ATSC-series HDTV tuners. Both remotes send the same IR codes, the difference is in how the tuner responds.

In most cases, IC-Net systems, especially for schools and other applications that access on-screen text menus and interactive media control, will continue to use the traditional IC-RC remote and mode.

System integrators can switch the ICC2-ATSC 4 to the HD2-RC mode to access HD features, such as channel scans and set up of 16:9 or 4:3 display modes. Then switch to IC mode to test iC-net operation and IC-Net device number.

Front-Panel Setup

The Front Panel modes are useful for setting tune mode, HD output and resolution, and switching between IC and HD2 remote modes.

IC Send Control

You'll find the free IC Send program to be a great tool for system setup and testing, especially if the site is using the ICE-HE Head End and your laptop is configured for the site's network. You can also use a PC or laptop via RS-232 with the ICC-HE Head End. Key functions include:

- **On, Off and Tune** commands to test operation to one or all ICC2-ATSC 4 units.
- **IR Mode.** Switch all tuners to IC or HD2 modes.
- **Channel Setup.** Use the T[^] Command to force all units to scan channels, then use the XA and XD commands to add and remove channels from the list. If you're using RS-232 control at the head end, have an ICC2-ATSC 4 at that location to check your setup.
- **Tuner Setup.** Use LM and TM commands to configure general tuner operation.
- **Default Input.** Use the ER command to set the default input.

Device Address Settings

Use the front-panel setting 2 and 3 to set the address. Menu 3 sets the Zone address, and Menu 2 sets the individual number in the zone. For example the system address for a controller is 257, set Menu 2 to 2.1 (1), and Menu 3 to 3.1 (Zone 1, which is address 256), $1 + 256 = 257$ system address. The controller will act by itself when you send the unique 257 code, as a zone group when you send 256, or with all with address 4095.

Zone	1	2	3	4	5	6	7	8
	256	512	768	1024	1280	1536	1792	2048
Zone	9	10	11	12	13	14	15	
	2304	2560	2816	3072	3328	3584	3840	

Front Panel Setup

To Enter a Front Panel Programming Mode:

1. Press **and hold** the Power button, then press the Volume Up button
2. Release all buttons, the ICC2-ATSC 4 will now be in the front-panel programming mode. The Air LED will flash, indicating programming mode.
3. The first two digits show the mode, the second show the option.
4. Changes are saved in non-volatile memory as they are entered.
5. The Volume up/down buttons scroll through programming modes, forward and reverse.
6. The Channel up/down buttons scroll through possible options for each mode.

To Exit the Front Panel Mode

Push and release the Power button.

Mode	0-9	Parameters
RF Tune	0.0	0=CATV (Default) 1=Off-Air 2=IRC 3=HRC 4=Cable Auto
Baud Rate	1.1 1.2 1.3 1.4 1.5 1.6 1.7	300 600 1200 2400 4800 9600 19200
Unit Number	2.1	1-99 (The LCD can't show a higher number. It's easier to use the Menu 999 function on the next page. Set IR Mode 18.1 to 18.0 to see the onscreen character generator. Once you're at the device # menu, you can enter the unit's address using the number keys on the IR remote.)
Zone Number	3.0	1-15 System device number is (Unit + (Zone * 256))
Panel Lockout	4.0	Reserved (performed by LM command)
Power-up Volume	5.0 5.X	Restore previous level (default) 1 – 63 sets volume level
Firmware Version	6.20	Ex: Version 2.0 - Press and hold Channel Up, then Power to restore tuner to default settings Press and hold Channel Up and Down, then Power to scan channels
Captions	10.0 10.1	Captioning off (default) Captioning on
Caption Mode	11.1 11.2 11.3 11.4 11.X	1=Caption 1 (default) 2=Caption 2 3=Caption 3 4=Caption 4 5-8= Text 1-4 (rarely used)
Video Detect	12.3	No AV mute (fixed)
AV Status	13.0	No AV status (default)
Label Mode	14.2	Numeric (fixed)
IR Receive	15.9	0= Off, 9=Receive IR
Digital Captions	17.1	1-6, Default is 1
IR Remote	18.1	0=IC-RC 1=HD2-RC
Tune Control	19.0	0=Tune all channels 1= Only tune channels in List
Digital Audio	47.0 47.1 47.2	0=AC-3– Dolby 5.1 1=PCM (set to this for audio through HDMI) 2=PCM Variable (default)
HD Output	48.0 48.2	RGB (Default) Component
HD Format	49.0 49.1 49.2 49.3 49.4	0=1080i (Default) 1=720p 2=480p 3=480i 4=1080p

RS-232 Control Codes

The following chart includes the current control codes for TVs and projectors. We add new codesets as needed.

The ICC2-ATSC 4 is shipped pre-loaded with the specific RS-232 code. Units can be updated to different control code sets via the RF. Almost all use 9600 baud, setting 1.6 on the tuner. Items in red are older codesets; we can add and test when needed.

MFG	Type	Notes
Full Operation		Responds to 0-NNN TV command for inputs
Barco 51	VP	115K Fixed baud rate, settings will not change baud
LG 54	LCD	V6.2
Mitsubishi 9	VP	
NEC 4	LCD	Older M-series monitors
NEC 48	LCD	New M, P, S, V, X series
Projection Design 44	VP	
Library		Responds to Input command, will be updated as needed
Eiki	VP	Have earlier codes, would need to verify
Epson 24	VP	
Christie 29	VP	19,2K setting 1.7
InFocus	VP	Have earlier codes, would need to verify
Hitachi 22	VP	19,2K setting 1.7
NEC 1 32	Plasma	Also versions for NEC E-series and M,P,V,X Monitors
Optoma	VP	Have earlier codes, would need to verify
Panasonic 6	LCD	
Pioneer	LCD	Have earlier codes, would need to verify
Samsung 10, 11, 27, 28,	LCD	
Sanyo 3	VP	19,2K setting 1.7
Sharp 1, 33, 46, 47	VP	VP and various monitors
Sony	VP	Have earlier codes, would need to verify
Sony	LCD	Have earlier codes, would need to verify
Specialty		
Extron	WP	Emulates Wall Panel buttons

Input Selects

The code sets listed in the **Full Operation** section have the ability to select inputs from a special channel command, 0-NNN. For example, a 0-211 command would send the TV to the HDMI 1 input. For some makes, such as LG, you need to send a TV/Tuner command (0-200) to restore the TV to the current channel. For other sets, sending a channel command automatically selects the tuner if it's at a different input. The command list covers all the possibilities, not all sets have every option. The LQ command can also change inputs in firmware 6.2 and higher.

115=Captions	206=Component1	211=HDMI1
200=TV/Tuner	207=Component2	212=HDMI2
201=Video1	208=RGB1	213=HDMI3
202=Video2	209=RGB2	214=HDMI4
203=Video3	210=RGB3	215=HDMI5
204=S-Video1		
205=S-Video2		

Input Command

You will need to specify the default input for the ICC1-ATSC+, so that the unit will return to the correct input. Use IC-Send or Display Express to send the EI command on page 15 to the tuner once it's on the IC-Net RF network.

HD2-RC IR Remote

The HD2-RC IR Remote can be used to setup the tuner and for daily operation. The IC-RC remote will work as well, the image below shows the function of the keys when the tuner is in the HD2-RC mode.

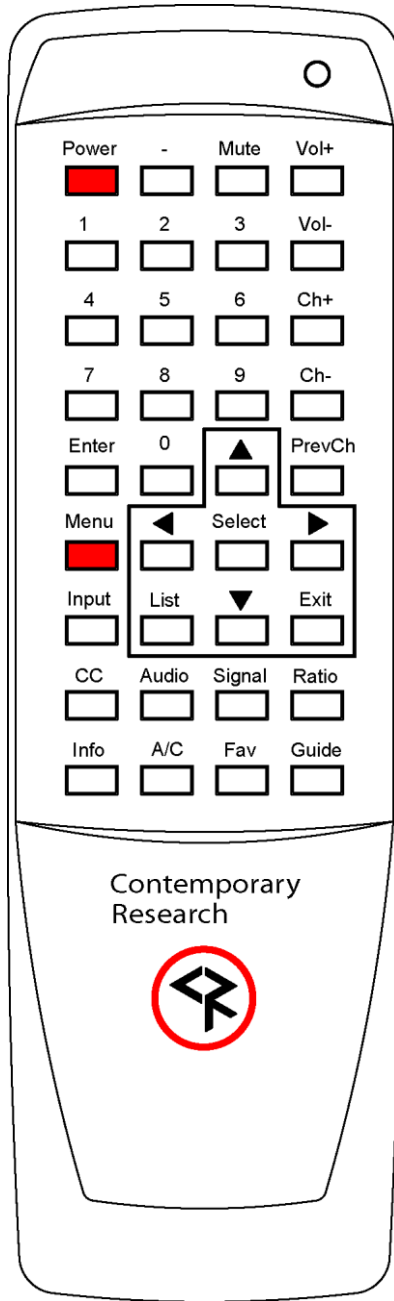

Power

Turns tuner on and off. Discrete on and off IR commands are available as well.

Volume Control

Use the **Vol+**, **Vol-** and **Mute** buttons.

Channel Selection

The key change in digital tuning is the need to add a dash (-) and number after the traditional channel number. Analog channels are accessed using XX-0, digital channels using XX-1 (or -2, -3, etc).

Ch+, **Ch-** and **PrevCh** can be used to access and recall channels.

Menu Operation

Press Menu to access the on-screen menus.

- Use the directional **Arrows**, **Select** and **Exit** to navigate the menus.
- **List** displays the list of all channels, arrow keys add/remove channels, set Favorite Channel list
- **Exit** steps backwards out of menus
- **Enter** selects menu choice

Special Functions

- **CC** steps through available closed-captioning options
- **Audio** selects audio and SAP modes
- **Signal** displays channel signal level
- **Ratio** steps through aspect ratios, options depend on channel and output types
- **Info** launches on-screen information window
- **A/C** selects Air or Cable tuning
- **Fav** Displays list of favorite channels
- **Guide** displays on-screen Guide

Features of many of the Special Function commands depend on whether the current channel is analog or digital.

IC-Net Control Protocol

Overview

RS-232 control for up to 4000 TV Controllers is provided through an iC-series Head-End Network Controller. The ICE-HE Ethernet Head End and ICC-HE Head End manage iC-Net communication over RF Coax to ICC1 (1-way) and ICC2 (2-Way) TV Controllers.

Each TV Controller is assigned a unique device number from 1 to 4000 to which control commands are addressed. The devices are organized into 16 zones of 255 devices. All the devices in each zone will respond to a single “virtual device number” — one device number that represents all devices in each zone. There is also a global device number, 4095, that will command all devices in the system. This feature dramatically speeds up system operation and programming, because one command can affect an entire group of devices—or all. To take advantages of this feature, review the section **iC-Net Zones** following this section.

In ABC-Net, we reserve the first group of devices, 1-255, for components operating on a connected control system. Zones 1-16 are used for CR TV Controllers, Video Display Controllers and Tuners. As it’s unlikely any system will use all 4000 devices, this may be a good device standard for your system as well.

The Remote RS-232 port on the Head-End Network Controller can communicate from 1200 to 38.4K baud. The factory default setting is 19.2K baud, 8 data bits, No parity, and 1 stop bit.

Command String Structure

Characters in command strings are expressed in a combination of hex and ASCII characters. For clarity, the following protocol examples use the following conventions, similar to AMX protocol, most other control systems would use Hex.

- Single-byte hex numbers are preceded by the ‘\$’ symbol
- ASCII characters or strings are enclosed in single quotes
- Numbers not marked as hex or ASCII are a single decimal byte
- Parameters shown in < > brackets are single byte
- A series of multiple commands or parameters are set apart by [] brackets
- Commas separate the bytes, but are not part of the protocol
- Double quotes enclose the command string, but are not part of the protocol

Command format:

“\$A5,<dh>,<dl>,<ncb>,<cmd1>,<parameter> [<cmdN>]”

\$A5	Starts the command
<dh>	The zone or high order byte of the device*
<dl>	The unit or low order byte of the device (0 for global zone)
<ncb>	The number of command bytes to follow, the (total bytes) shown after are simply reference
<cmd1>	The first command byte
<parameter>	Command parameters (not used by all commands)
[<cmdN>]	Multiple commands can be concatenated, with byte count added to <ncb>

* iC-Net devices are arranged with a zone mindset. For example, a command sent to Device 256, which triggers all the units in Zone 1, would be expressed as \$A5, 1, 0 (first zone, device zero). A command sent to 257 would be \$A5, 1, 1 (first zone, device 1 in the zone). See iC-Net Zones following this section.

IC-Net Commands

Command	Description	
Control		
Power Off	P0	"\$A5,<dh>,<dl>,2,'P0' " (6 bytes)
Power On	P1	"\$A5,<dh>,<dl>,2,'P1' " (6 bytes)
Power Toggle	PT	"\$A5,<dh>,<dl>,2,'PT' " (6 bytes)
Volume	VL	"\$A5,<dh>,<dl>,3,'VL',<vol level>" (7 bytes) Sets TV volume level 0 = Mute 1 – 63 = Minimum level (1) to maximum volume (63)
RS-232 Control	T0	Not applicable for the ICC2-ATSC 4
IR Remote	Q8=	"\$A5,<dh>,<dl>,3,'Q8',<IR Remote>" (7 bytes) 0=IC-RC 1=HD2-RC
Control Lock	LM	"\$A5,<dh>,<dl>,3,'LM',<control>" (7 bytes) Locks out front panel and IR remote control functions. Bit 7 Selects IR remote control operation (0=enabled, 1=disabled) Bit 6 Selects volume control operation (0=enabled, 1=disabled) Bit 5 - 1 Always 0 Bit 0 Selects front panel buttons operation (0=enabled, 1=disabled)
Operating Parameters	TM	"\$A5,<dh>,<dl>,3,'TM',<setting>" (7 bytes) Sets up key functions in the unit Bit 0 – Alpha channel labels 0=alpha labels off 1=alpha labels on Bit 1 – Numeric channel labels, 0=num labels off 1=num labels on Bit 2 – Channel up/down operation, 0=Tune Ring, 1=Send IR Keypad response Bit 3-7 = 0
Control String	UX	"\$A5,<dh>,<dl>,2+string length>,'UX'<string>" (variable bytes) Sends an RS-232 string (ASCII, decimal, or hex) directly to the TV display. Ex: "\$A5,1,2,6,'UX', 'PON', 13" Sends PON, followed by carriage return (device 258)
Baud Rate	R5=	Set Baud Rate 1=300 2=600 3=1200 4=2400 5=4800 6=9600 7=19200
Inputs	LQ=	"\$A5,<dh>,<dl>,3,'LQ',<IR Code>" (7 bytes) 200=TV/Tuner 208=RGB 1 201=Video1 209=RGB 2 202=Video2 210=RGB3 203=Video3 211=HDMI1 204=S-Video1 212=HDMI2 205=S-Video2 213=HDMI3 206=Component1 214=HDMI4 207=Component2 215=HDMI5

Command	Description	
Tuning		
Tuning Format	S0=	<p>"\$A5,<dh>,<dl>,3,'S0',<format>" (7 bytes)</p> <p>0=CATV 1=Off-Air 2=IRC 3=HRC 4=Cable Auto</p>
Tuning Style	H1=	NA
TC Response	H2=	NA – When the ICC2-ATSC 4 receives an analog channel command, it will attempt to tune the digital equivalent first. If there is not a matching virtual channel, the unit will tune the analog channel.
Channel Up	TU	"\$A5,<dh>,<dl>,2,'TU' " (6 bytes) – Tunes to next channel up
Channel Dwn	TD	"\$A5,<dh>,<dl>,2,'TD' " (6 bytes) – Tunes to next channel down
Prev Channel	TP	"\$A5,<dh>,<dl>,2,'TP' " (6 bytes) – Tunes to previous channel
Tune Analog Channel	TC	"\$A5,<dh>,<dl>,3,'TC', <channel>" (7 bytes) – Tunes to a specific channel 2-127
Scan Mode	D0=	<p>"\$A5,<dh>,<dl>,3,'D0',<mode>" (7 bytes) – Scan Mode</p> <p>Sets scan mode for digital and analog channels from the T^ or front panel scan command.</p> <p>0= Scans for analog and digital channels scan (default) 1= Scans for digital only, deletes analog channels 2= Scans for digital only, keeps analog channels 3= Scans for analog only, deletes digital channels 4= Scans for analog only, keeps digital channels</p>
Channel Scan	T^	"\$A5,<dh>,<dl>,2,'T^' " (6 bytes) – Initiates channel scan
Tune HD Channel	TH=	<p>"\$A5,<dh>,<dl>,5,'TH',<H1>,<Major>,<Minor>" (9 bytes)</p> <p>The tuner will ignore the first bit (H1), and tune the major (virtual) and minor channels. Values may be in hex or decimal.</p> <p>Ex: "\$A5,1,4,5,'TH',0,2,3" Device 260, virtual channel 2-3</p> <p>The LQ command and TH 0-xxx (p10) can select inputs</p>
Add Channel	XA=	Not applicable for the ICC2-ATSC 4
Delete Channel	XD=	Not applicable for the ICC2-ATSC 4
Tune Control	Q9=	Not applicable for the ICC2-ATSC 4
Captions	Q0=	<p>"\$A5,<dh>,<dl>,3,'Q0',<on-off>" (7 bytes)</p> <p>0=Captioning off (default) 1=Captioning on</p>
Caption Mode	Q1=	<p>"\$A5,<dh>,<dl>,3,'Q1',<mode>" (7 bytes)</p> <p>1=Caption 1 (normal setting for most captioning) 2=Caption 2 3=Caption 3 4=Caption 4 5-8= Text 1-4 (rarely used)</p>

Command	Description																					
Tuning																						
Input	EI	<p>"\$A5,<dh>,<dl>,3,'EI',<Input>" (7 bytes)</p> <p>Sets the input for controlled projector or display. See Input list in ER.</p>																				
Input Ring	ER	<p>"\$A5,<dh>,<dl>,<ncb>,'ER', [<input 1>, <input N>]" (variable bytes)</p> <p>Sets a list of inputs that are cycled by the Input command on the IC-IR remote or KK command. Follow the standard list of inputs below, check with CR Support on which are available for your make and model of video display.</p> <table border="0"> <tr> <td>1 Video1</td> <td>11 DVI/HDMI1</td> </tr> <tr> <td>2 Video2</td> <td>12 DVI/HDMI2</td> </tr> <tr> <td>3 Video3</td> <td>13 DVI/HDMI3</td> </tr> <tr> <td>4 S-Video1</td> <td>14 DVI/HDMI4</td> </tr> <tr> <td>5 S-Video2</td> <td>15 DVI/HDMI5</td> </tr> <tr> <td>6 Component1</td> <td>16 TV</td> </tr> <tr> <td>7 Component2</td> <td>17 TV2</td> </tr> <tr> <td>8 RGB1</td> <td>18 1394</td> </tr> <tr> <td>9 RGB2</td> <td>19 Memory stick</td> </tr> <tr> <td>10 RGB3/DTV</td> <td></td> </tr> </table> <p>Ex: "\$A5,<dh>,<dl>,6,'ER', 1,4,8,11" sets ring to Inputs 1, 4, 8 and 11.</p>	1 Video1	11 DVI/HDMI1	2 Video2	12 DVI/HDMI2	3 Video3	13 DVI/HDMI3	4 S-Video1	14 DVI/HDMI4	5 S-Video2	15 DVI/HDMI5	6 Component1	16 TV	7 Component2	17 TV2	8 RGB1	18 1394	9 RGB2	19 Memory stick	10 RGB3/DTV	
1 Video1	11 DVI/HDMI1																					
2 Video2	12 DVI/HDMI2																					
3 Video3	13 DVI/HDMI3																					
4 S-Video1	14 DVI/HDMI4																					
5 S-Video2	15 DVI/HDMI5																					
6 Component1	16 TV																					
7 Component2	17 TV2																					
8 RGB1	18 1394																					
9 RGB2	19 Memory stick																					
10 RGB3/DTV																						
Text																						
Write Text	DM	<p>"\$A5,<dh>,<dl>,<ncb>,'DM', <start line>,<text color>,<text background color>, <screen background>,<size and shadow>,<timeout>,<message bytes>" (variable bytes)</p> <p>Clears current text, displays text message over video (default) or blank background. The built-in character generator can accept up to 40 characters of text (including carriage returns), 28 characters per line. Use a hex \$0D or decimal 13 in the text as a carriage return, which will advance CG to the next line, first space on the right.</p> <p>Start Line - 1-9 Text Color - 1-7= White Text Background Color – 0-7=Transparent (no background) Full screen background – 0=normal insert over video Size and Shadow – 0-3=small text with drop shadow Time-Out – 0=15-second display, 1=persistent</p> <p>Persistent text stays on screen until the next DM, or new Menu or channel.</p> <p>Ex1: "\$A5,<dh>,<dl>,10,'DM', 2,7,0,0,1,0,'TEST' " displays the word TEST on the second line, white text, inserted over video, small size with drop shadow, and timing out after 15 seconds.</p> <p>Ex2: "\$A5,<dh>,<dl>,2,'DM' " clears on-screen display, also clears persistent text</p> <p>The ATSC uses white text and clear backgrounds when it receives a Text or Background Color parameter between 1 and 7, and accepts values 0-3 for text size and shadow. This allows compatibility with Smart TVs mixed in the same system that can display other colors and fonts.</p>																				
Return	EB	<p>"\$A5,<dh>,<dl>,2,'EB' " (6 bytes)</p> <p>Moves cursor down to the first column of the next row.</p>																				
Text Timeout	DQ	<p>"\$A5,<dh>,<dl>,3,'DQ', <time>" (7 bytes)</p> <p>Sets screen timeout to specified time in seconds (1-254). If time is 0 or 255, any text on the screen will persist indefinitely, or until cleared.</p>																				

HD2-RC Remote Emulation

You can also emulate IR commands sent from the CR HD2-RC Wireless Remote. If you are using the numeric keys to select a channel, the user or program will need to follow the numeric command with an Enter.

KK=<key>	"\$A5,<dh>,<dl>,3,'KK',<control>" (7 bytes)	
	* = Reserved for future products/applications	
0=*		88=Favorite
1=*		95=List
2=*		96=Add/Delete Channel
3=*		98=Air/Cable
4=*		99=Dash -
5=*		100=Info
6=*		101=Prev Chan
7=*		105=Menu
8=*		106=Cur Rt
9=Power (tog)		107=Cur Lt
10=0		108=Cur Up
11=1		109=Cur Dn
12=2		110=Select
13=3		111=Exit
14=4		115=CC
15=5		141=Format 1080i
16=6		142=Format 720p
17=7		143=Format 480p
18=8		144=Format 480i
19=9		145=Format 1080p
20=		149=Output RGB
21=Enter		151=Output YPbPr
22=Ch Up		153=Air
23=Ch Dn		154=Cable
24=Vol Up		155=Aspect ratio pillar/letter box
25=Vol Dn		156=Aspect ratio full/wide
26=Vol Mute (tog)		157=Aspect ratio zoom
27=Power On		158=AC-3(Dolby 5.1)
28=Power Off		159=PCM
29=Menu		160=PCM Variable
63=Guide		161=16:9
80=Freeze		162=4:3
81=Signal		
82=Ratio		
85=Audio		

IC-Net Response

Response	Description
New Channel	<p>T “ ‘<, <dh>, <dl>, 2, 'T', <new channel>” (6 bytes)</p> <p>Sent in response to T? command.</p>
IR Function	<p>R “ ‘<, <dh>, <dl>, 2, 'F', <IR Function>” (6 bytes)</p> <p>Sent when unit receives a new function command is pressed (1-8) or released (0) from the IR remote.</p> <p>0 = Release 1 = Play 2 = Stop 3 = Pause 4 = Fast Forward 5 = Rewind 8 = Record</p>
IR Key	<p>K “ ‘<, <dh>, <dl>, 2, 'K', <IR Key>” (6 bytes)</p> <p>Sent when unit receives a new key command is pressed (10-23) or released (0) from the IR remote.</p> <p>0 = Release 10 - 19 = Numeric keypad entry 0 – 9 21 = Enter 22 = Channel Up 23 = Channel Down 29 = Menu 101 = Previous Channel 102 = Timer 105 = Media Menu 107 = Cursor Left 108 = Cursor Up 109 = Cursor Down 110 = Media Select</p> <p>The 0 – 9, Channel Up/Down functions are sent only if enabled in the TM command (Bit 2 = 1). The Channel Up/Down responses will be sent if the Tune Ring contains no channels – see Ex2 in the Tune Ring command section.</p>
IR Menu	<p>M “ ‘<, <dh>, <dl>, 5, 'M', <msh>, <msl>, <mph>, <mpl>” (9 bytes)</p> <p>Sent when unit receives a new Menu command is pressed or released (0) from the IR remote. Menu Selection high and low bytes are in <msh> and <msl>. Menu Parameter high and low bytes are in <mph> and <mpl>.</p> <p>A Menu command is initiated by pressing the Menu key, followed by a numeric entry, then the Enter or Channel Up key. During the Menu process, the Channel Down key acts as a backspace or delete key.</p> <p>Some selections that need only a single numeric entry and will have a parameter value of zero (0). Those keys are 0, 8, 9, 18, 20, 30, 900, 911, and 912.</p> <p>Menu selections that will prompt the user to enter a second parameter entry are:</p> <p>1 = Select Media 2 = Password 3 = Chapter Search 4 = Frame Search 11 = Channel 21 = Page Zone 22 = Page Room 25 = Go 21 = Attach Zone 32 = Attach Room</p> <p>Tip: The Menu entries are active even if the TV power is off.</p>

iC-Net Zones, Units and Device Addresses

In the front-panel setup instructions, you set the Unit # (1-255), then the Zone # (1-15). This refers to the iC-Net address structure that includes device number 256 – 4095 that is divided up into 15 Zones.

To simplify controlling groups of devices, iC-Net is divided into 15 zones of 255 devices, called SmartZones. All the devices within each zone can be controlled simultaneously by sending a command to a single virtual device number.

For example, noting the zone chart below, if we send a Power On command to device #256, all iC-Net controllers in Zone 1 will turn off at the same time.

This is an immensely powerful feature, because most systems can only address one device at time. If you need to turn off all 50 TV in a zone, you would need to send 50 commands. In addition to the hassles of creating multiple commands, there would be a long delay between the first and last command. One command, instant response is easier.

The Zone number plus the Unit number equals the actual device address.

Zone	Device #	Unit	Total Device #
1	256	1-255	257-511
2	512	1-255	512-767
3	768	1-255	769-1023
4	1024	1-255	1025-1279
5	1280	1-255	1281-1535
6	1536	1-255	1537-1791
7	1792	1-255	1793-2047
8	2048	1-255	2049-2303
9	2304	1-255	2305-2559
10	2560	1-255	2561-2815
11	2816	1-255	2817-3071
12	3072	1-255	3073-3327
13	3328	1-255	3329-3583
14	3584	1-255	3585-3839
15	3840	1-255	3841-4000
All Zones	4095		





Tip: While many applications can use just the Zone number, it's a good practice to assign a unique Unit number to each controller in the zone. This allows the system software to address individual controllers if necessary.





System Map





One of the key tasks for iC-Net integrators is to create a logical **System Map**, assigning device numbers to TV controllers so they fall into physical zones useful to the client. The device mapping could be sorted by type or location; whichever suits the application.





iC-Net Zone	Zone	Room	Unit	Device
1	W 1 st Floor			256
		W151	1	257
		W152	2	258
		W153	3	259
		W154	4	260
2	W 2 nd Floor			512
		W251	1	513
		W252	2	514
		W253	3	515
		W254	4	516
3	E 1 st Floor			768
		E151	1	769
		E152	2	770
		E153	3	771
		E154	4	772
4	E 2 nd Floor			1024
		E251	1	1025
		E252	2	1024
		E253	3	1025
		E254	4	1026
5	Cafes			1280
		G100	1	1281
		G150	2	1282
		G151	3	1283
6	Entrance			1536
		TV 1	1	1537
		TV 2	2	1538
7	Hallways			1792
		W1	1	1793
		W2	2	1794
		E1	3	1795
		E2	4	1796
8	Concession			2048
		Lower	1	2049
		Upper	2	2050
All Zones	All			4095

On-Screen Menus

<p>Main Menu</p> 	<p>Selects sub-menus.</p> <ul style="list-style-type: none"> • Arrow keys highlight option • Select (or Enter) chooses option • Menu steps back or exits menu • Exit exits all menus • Some options are only available if you are currently tuned to an analog or digital channel
<p>Channel Menus</p> 	<p>Sub-Menu for Channels offers options for:</p> <ul style="list-style-type: none"> • Channel Auto-Scan • Favorite Channel Selection • Add/Delete Channels • Fine Tune (If tuned to an analog channel) • Signal Strength Meter
<p>Auto-Scan</p> 	<p>Starts scan of analog and digital channels for:</p> <ul style="list-style-type: none"> • Air – looks for NTSC and ATSC channels • Cable Auto – looks for analog and digital QAM cable channels, as well as all frequency plans • Cable STD - standard cable spacing • Cable HRC – HRC cable spacing • Cable IRC – IRC cable spacing <p>Tip: Normally, use Auto. Most cable channels will be in standard frequencies. If all the channels tune in STD but channels 5 and 6, scan for IRC. If few channels can be found, scan for HRC.</p>
<p>Favorite Channels</p> 	<p>Menu is also displayed from the List command, selects channels advanced by the FAV favorite channel command.</p> <p>Use the Up, Down arrows to move through the list, press Select to add a channel to Favorites.</p>

<p>Channel Add/Delete</p> 	<p>This menu can add or delete a channel accessed from Channel Up and Down.</p> <p>You can tune to a channel you want to delete, then press Menu/Channel/Add-Delete. Press Select to delete the channel. You can also keep the page on screen as you step through channels, adding and deleting as desired. If the channel has a good signal, it will be displayed in the background.</p> <p>Note that HDTV channels are broadcast on UHF frequencies. The Add/Delete will show the name of the digital channel, as well as the actual UHF channel used for broadcasting.</p> <p>You can delete one of a digital channel's sub-channels without affecting the others.</p>
<p>Signal Strength</p> 	<p>This page also displays from the Signal remote command. The graphic shows the current signal strength, and changes in real time. This allows you to monitor the strength of a channel as you adjust the antenna for best reception.</p>
<p>Caption Menus</p>	
	<p>This menu accesses captioning features:</p> <ul style="list-style-type: none"> • On/Off – turn captions on/off – <i>other options are not available if captions are off.</i> • Analog Mode - CC 1-4 and Text 1-4 • Digital Mode – Service 1-6 • Digital Font Options <ul style="list-style-type: none"> • Size – Standard (15 pixels), Large (21 pixels), or Small (11 pixels) • Style – 1-6 • Color – 8 shade of background, foreground and edge colors • Opacity – foreground and background • Edge – 6 style options <p>Version displays current version of tuner firmware</p>
<p>V-Chip Settings Menus</p>	
	<p>Manages access to programming for US and Canadian standards.</p> <p>The default PIN number for access is 0000 (four zeros).</p>

<p>Change PIN</p> 	<p>Enter and confirm new PIN for access.</p>																																																	
<p>US Rating</p>  <table border="1" data-bbox="224 575 532 743"> <thead> <tr> <th>MOVIE</th> <th>TV</th> <th>FV</th> <th>D</th> <th>L</th> <th>S</th> <th>V</th> </tr> </thead> <tbody> <tr> <td>G</td> <td>TV-Y</td> <td></td> <td></td> <td></td> <td></td> <td></td> </tr> <tr> <td>PG</td> <td>TV-Y7</td> <td></td> <td></td> <td></td> <td></td> <td></td> </tr> <tr> <td>PG13</td> <td>TV-G</td> <td></td> <td></td> <td></td> <td></td> <td></td> </tr> <tr> <td>R</td> <td>TV-PG</td> <td></td> <td></td> <td></td> <td></td> <td></td> </tr> <tr> <td>NC17</td> <td>TV-14</td> <td></td> <td></td> <td></td> <td></td> <td></td> </tr> <tr> <td>X</td> <td>TV-MA</td> <td></td> <td></td> <td></td> <td></td> <td></td> </tr> </tbody> </table>	MOVIE	TV	FV	D	L	S	V	G	TV-Y						PG	TV-Y7						PG13	TV-G						R	TV-PG						NC17	TV-14						X	TV-MA						<p>Use arrows and Select functions to select level of Movie and TV rating allowed.</p>
MOVIE	TV	FV	D	L	S	V																																												
G	TV-Y																																																	
PG	TV-Y7																																																	
PG13	TV-G																																																	
R	TV-PG																																																	
NC17	TV-14																																																	
X	TV-MA																																																	
<p>Canada Rating</p>  <table border="1" data-bbox="224 909 532 1098"> <thead> <tr> <th></th> <th>English</th> <th>French</th> </tr> </thead> <tbody> <tr> <td>Allow All</td> <td>E</td> <td>E</td> </tr> <tr> <td>Block All</td> <td>C</td> <td>G</td> </tr> <tr> <td></td> <td>C8+</td> <td>8+</td> </tr> <tr> <td></td> <td>G</td> <td>13+</td> </tr> <tr> <td></td> <td>PG</td> <td>16+</td> </tr> <tr> <td></td> <td>14+</td> <td>18+</td> </tr> <tr> <td></td> <td>18+</td> <td></td> </tr> </tbody> </table>		English	French	Allow All	E	E	Block All	C	G		C8+	8+		G	13+		PG	16+		14+	18+		18+		<p>Use arrows and Select functions to select level of Movie and TV rating allowed.</p>																									
	English	French																																																
Allow All	E	E																																																
Block All	C	G																																																
	C8+	8+																																																
	G	13+																																																
	PG	16+																																																
	14+	18+																																																
	18+																																																	
<p>Setup Menus</p>																																																		
	<p>This series of menus select the options for tuner operation:</p> <ul style="list-style-type: none"> • Screen Format – 16:9 or 4:3 NOTE: Set when tuned to a digital channel, again when tuned to an analog channel – these are two different settings! You can use RATIO on the remote – does the same setting. • Time • Sound Settings • Video Noise Reduction - On/Off (if tuned to analog) Set to On – helps to clean up analog channels • Menu Language – English, Spanish, French 																																																	

<p>Screen Format</p> 	<p>Selects between 4:3 and 16:9 aspect ratios. The Ratio command can also adjust the settings.</p> <ul style="list-style-type: none"> • 4:3 Display offers three options for 16:9 video: 16:9, 4:3 (stretched vertically), and Zoom (cropped sides) • 16:9 Display offers three options for 4:3 video: 4:3 (small centered), 16:9 (stretched horizontally), and Zoom (stretched vertically and horizontally) – or 4:3 and 16:9 if the video is 16:9
<p>Time</p> 	<p>Sets time settings for:</p> <ul style="list-style-type: none"> • Daylight Saving – Select and choose on or off Note – The DST trigger comes from the broadcast stations, and may not be in sync with the new US standards. Use On/Off or time zone to offset time • Time Zone – Select local time Zone
<p>Time Zone</p> 	<p>Use left-right cursors to select the time zone, Select enters the current zone.</p>
<p>Sound</p> 	<p>Selects a variety of options, each is only active when you are currently tuned into an analog or digital channel:</p> <ul style="list-style-type: none"> • Analog MTS – Mono, Stereo, SAP (same as Audio) • Multi-Track – English, French, Spanish • Digital Out – AC-3 (Dolby 5.1), PCM, or variable-level PCM. Set to PCM when using audio through the HDMI connection – most displays cannot decode AC-3 (Dolby 5.1). • Auto Volume – On or off
<p>Pop-Up Menus</p>	 <p style="text-align: center;">Info Guide</p>

Safety Instructions

Read before operating equipment.

- Cleaning - Unplug this product from the wall outlet before cleaning. Do not use liquid cleaners or aerosol cleaners. Use a damp cloth for cleaning.
- Power Sources - Use supplied or equivalent UL/CSA approved low voltage DC plug-in transformer.
- Outdoor Antenna Grounding - If you connect an outside antenna or cable system to the product, be sure the antenna or cable system is grounded so as to provide some protection against voltage surges and built-up static charges. Section 810 of the National Electrical Code, ANSI/NFPA No. 70, provides information with respect to proper grounding of the mast and supporting structure, grounding of the lead-in wire to an antenna discharge unit, size of grounding conductors, location of antenna discharge unit, connection to grounding electrodes, and requirements for the grounding electrode.
- Lightning - Avoid installation or reconfiguration of wiring during lightning activity.

Power Lines - Do not locate an outside antenna system near overhead power lines or other electric light or power circuits or where it can fall into such power lines or circuits. When installing an outside antenna system, refrain from touching such power lines or circuits, as contact with them might be fatal.

- Overloading - Do not overload wall outlets and extension cords as this can result in a risk of fire or electric shock.
- Object and Liquid Entry - Never push objects of any kind into this product through openings as they may touch dangerous voltage points or short out parts, resulting in a fire or electric shock. Never spill liquid of any kind on the product.
Servicing - Do not attempt to service this product yourself as opening or removing covers may expose you to dangerous voltage or other hazards. Refer all servicing to qualified service personnel.
- Damage Requiring Service - Unplug this product from the wall outlet and refer servicing to qualified service personnel under the following conditions:
 - When the power supply cord or plug is damaged.
 - If liquid spills or objects fall into the product.
 - If the product is exposed to rain or water.
 - If the product does not operate normally by following the operating instructions. Adjust only those controls that are covered by the operating instructions. An improper adjustment of other controls may result in damage and will often require extensive work by a qualified technician to restore the product to its normal operation.
 - If the video product is dropped or the cabinet is damaged.
 - When the video product exhibits a distinct change in performance, this indicates a need for service.

* Note to CATV system installer: This reminder is provided to call CATV system installer's attention to Article 820-40 of the National Electrical Code (Section 54 of Canadian Electrical Code, Part I), that provides guidelines for proper grounding and, in particular, specifies that the cable ground shall be connected to the grounding system of the building as close to the point of cable entry as possible.

Limited Warranty and Disclaimer

Warranty: Three (3) year limited warranty on all parts and labor for Contemporary Research manufactured products from the day of purchase by authorized dealer. Manufactured products are warranted against defects in materials and workmanship. If Contemporary Research receives notice of such defects during the warranty period, Contemporary Research will repair or replace, at its option, products that prove to be defective.

Exclusions: The above warranty shall not apply to defects resulting from improper or inadequate maintenance by the customer, customers applied software or interfacing, unauthorized modifications or misuse, mishandling, operation outside the normal environmental specifications for the product, use of the incorrect, modified or extended power supply, or improper site operation and maintenance. *Please note Contemporary Research SSV-DX Display Express PC product carries a six month limited warranty.*