

2807

Mini-Node CATV Optical Receiver



Features

- Wide Bandwidth of 50 to 860 MHz Accommodates Up to 110 Channels on All Models
- Provides Excellent Picture Quality with a CNR up to 54.5 dB, CSO of -63 dBc and CTB of -66 dBc
- Provides up to +38 dBmV RF Output Power Over the Entire Optical Input Range, Allowing a Greater Number of Drops or Splits
- Wide Optical Input Range of -8 dBm to +4.5 dBm Permits the Use of a Lower Power Transmitter, Reducing System Cost
- Capable of Responding to Changing System Requirements with Field-Installable Return Path Modules
- Digitally Adjustable Built-In RF Attenuator and Equalizer Settings Allow for Accurate Adjustment of Parameters Via an LCD Screen

The 2807 Mini-Node CATV Optical Receiver, working with either the 2804 PDS or 2805 PNS transmitter, provides CATV distribution head end operators with an extensive array of features that offer a low-cost solution to increase system performance. The receiver provides an RF output of +38 dBmV over the entire optical input range allowing multiple RF splits without the use of an external RF amplifier. Additionally, the mini-node's ability to operate over a wide optical input range of -8 to +4.5 dBm allows for a variety of system designs without degrading performance. An LCD display enables the operator to accurately set the tilt and RF output levels to ensure quality of service. The 2807 mini-node can be ordered either with or without the return path transmitter module. A separate return path module may also be ordered, allowing for a quick factory upgrade or laser replacement. The return path module utilizes either an FP or DFB laser. The modular design of the 2807 offers the flexibility and performance demanded by today's broadband professional.

77/110 Channel Mini-Node Receiver Part Numbers

Description	Part Number (SC/APC Optical Connector)	Part Number (FC/APC Optical Connector)
Mini-Node Receiver, No Return Path	2807NA-SFSP	2807NA-SFAP
Mini-Node Receiver, 1.5 mW FP Laser, 1310 nm, Return Path	2807NB-SFSP	2807NB-SFAP
Mini-Node Receiver, 3.0 mW DFB Laser, 1310 nm, Return Path	2807NC-SFSP	2807NC-SFAP
Mini-Node Receiver, 3.0 mW DFB Laser, 1550 nm, Return Path	2807ND-SFSP	2807ND-SFAP

Note: Power Supply Part Number PS200 included.

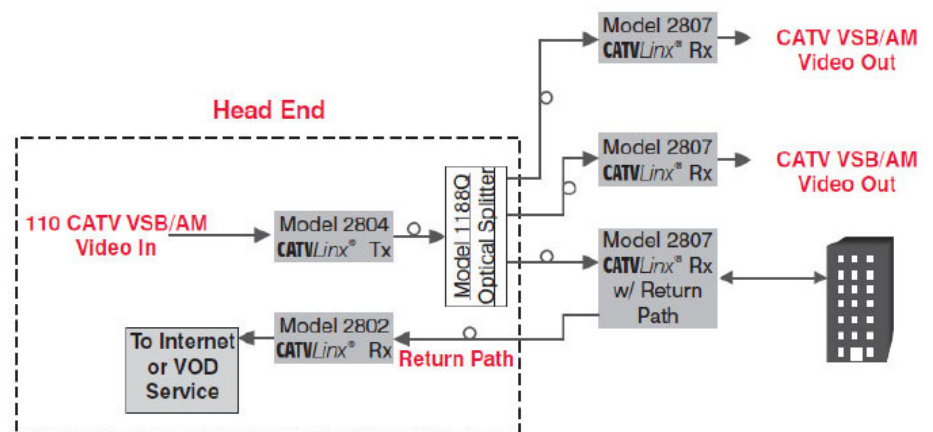

Mini-Node CATV Optical Receiver

RF & Optical Characteristics

Parameter	Min	Typ	Max	Units
CATV RECEIVER				
Optical Input Power	-8.0	0.0	+4.5	dBm
Channel Loading	-	-	110	Ch.
Operating Wavelength	1290	1310	1330	nm
Operating Wavelength	1490	1550	1610	nm
Bandwidth	50	-	860	MHz
Output RF Impedance	-	75	-	Ohms
RF Output Level	-	-	+38	dBmV
RF Output Return Loss	-	16	-	dB
Backreflection Tolerance	-	-	-50	dB
Required Fiber Bandwidth	2,000	-	-	MHz
Composite Second Order (CSO)	-	-63	-	dBc
Composite Triple Beat (CTB)	-	-66	-	dBc
Carrier-to-Noise Ratio		See Graph		dB
RETURN PATH MODULES				
Operating Wavelength	1290	1310	1330	nm
Operating Wavelength	1490	1550	1610	nm
Optical Output (FP Laser)	-	1.5	-	mW
Optical Output (DFB Laser)	-	3.0	-	mW
Bandwidth	5	-	42	MHz

System performance specifications indicated for use with 9/125 μ m singlemode fiber.

Electrical Characteristics

Parameter	Min	Typ	Max	Units
Power Supply Voltage	+10	+12	+15	V _{DC}
Power Dissipation	-	10	-	Watts

Physical Characteristics

Parameter	Min	Typ	Max	Units
Weight	-	1.0 283.5	-	oz g
Dimensions	-	8.45 x 2.95 x 1.75 215 x 75 x 45	-	in mm

Environmental Characteristics

Parameter	Min	Typ	Max	Units
Operating Temperature Range	0	-	+50	°C
Storage Temperature Range	-20	-	+70	°C
Humidity (RH, non-condensing)	5	-	95	%

Carrier-to-Noise Performance

