

90 DAY LIMITED WARRANTY

Winegard Company warrants this Winegard product against any defects in materials or workmanship within 90 (ninety) days from date of purchase. No warranty claim will be honored unless at the time the claim is made, you present proof of purchase to an authorized Winegard dealer (if unknown, please contact Winegard Company, 3000 Kirkwood Street, Burlington, IA 52601-2000, Telephone 800-288-8094).

Winegard Company (at its option) will either repair or replace the defective product at no charge to you. This warranty covers parts, but does not cover any costs incurred in removal, shipping or reinstallation of the product. This limited warranty does not apply if the product is damaged, deteriorates, malfunctions or fails from: misuse, improper installation, abuse, neglect, accident, tampering, modification of the product as originally manufactured by Winegard, usage not in accordance with product instructions or acts of nature such as damage caused by wind, lightning, ice or corrosive environments such as salt spray and acid rain.

The 90 Day Warranty is provided on the condition that the equipment is properly delivered with all handling and freight charges prepaid to your Winegard dealer for return to our factory for repair or replacement. Winegard dealers will arrange for the replacement or repair and return to you without charge the product which failed due to defective material or workmanship.

WINEGARD COMPANY WILL NOT ASSUME ANY LIABILITIES FOR ANY OTHER WARRANTIES, EXPRESS OR IMPLIED, MADE BY ANY OTHER PERSON.

ALL OTHER WARRANTIES WHETHER EXPRESS, IMPLIED OR STATUTORY INCLUDING WARRANTIES OF FITNESS FOR A PARTICULAR PURPOSE AND MERCHANTABILITY ARE LIMITED TO THE 90-DAY PERIOD OF THIS WARRANTY.

The foregoing shall be the sole and exclusive remedy of any person, whether in contract, tort or otherwise, and Winegard shall not be liable for incidental or consequential damage or commercial loss, or from any other loss or damage except as set forth above.

Some states do not allow limitations on how long an implied warranty lasts, or the exclusion of limitation of incidental or consequential damages, so the above limitations or exclusions may not apply to you.

This warranty gives you specific legal rights and you may also have other rights which vary from state to state.

Rev. 2/08



High Definition (HD) Platinum Antennas UHF MODELS HD9075P, HD9095P

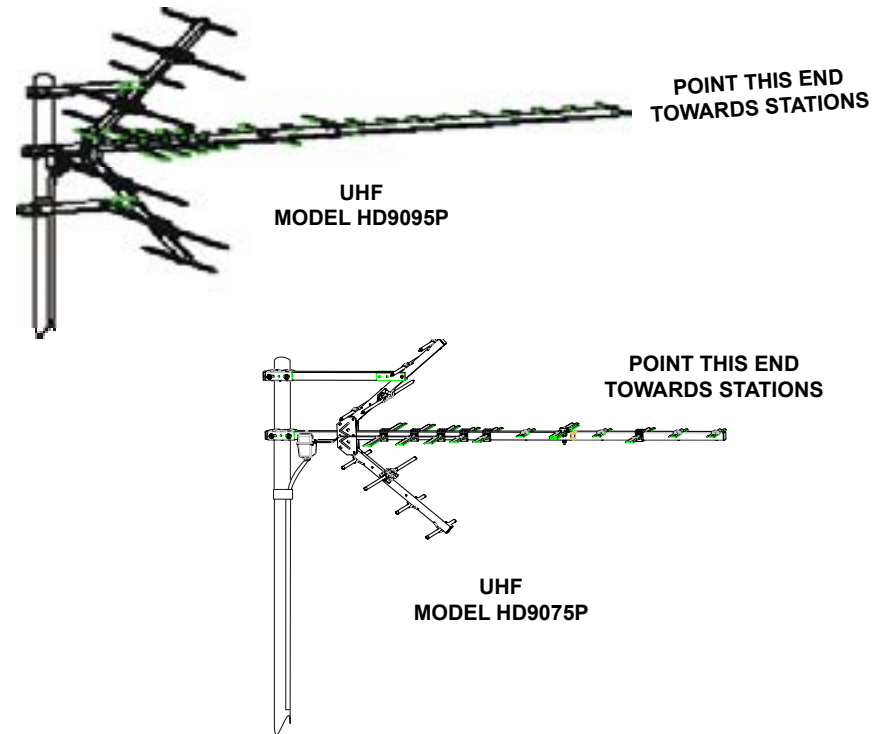

Register your product at winegard.com/myantenna

WARNING

INSTALLATION OF THIS ANTENNA NEAR POWER LINES IS DANGEROUS.
FOR YOUR SAFETY, FOLLOW THE INSTALLATION INSTRUCTIONS.

WARNING

INSTALLATION OF THIS ANTENNA NEAR POWER LINES IS DANGEROUS. FOR YOUR SAFETY, FOLLOW THE INSTALLATION INSTRUCTIONS.

STEP 1. Unfold the elements on the top and bottom reflector booms. Swing the elements out until they lock into position. See Fig. 1.

Fig. 1

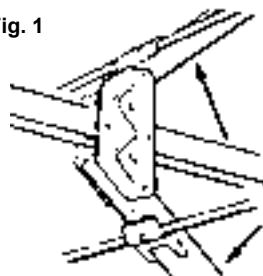

STEP 2. Unfold the reflector booms making sure they lock into place.

Fig. 2

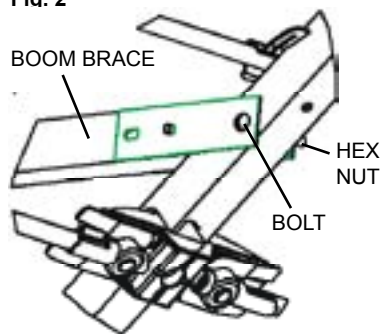

STEP 3. Remove the bolt and hex nut from the boom brace. Attach the boom brace to the top reflector boom (cartridge housing should be on bottom of antenna) so mast clamps are on the same side. Replace the bolt and hex nut. Tighten securely. See Figure 2. (HD9095P has a top & bottom brace.)

HD9095P

STEP 4. Remove the bolt and hex nut holding the element on the tapered end of the front boom. Slide the two sections together. The elements should be on top (cartridge housing on the bottom of the antenna). Replace the element, bolt and hex nut and tighten securely. See Figure 3.

Fig. 3



STEP 5. To attach the cartridge housing to the antenna, align the snaps on the cartridge housing with the snap holes on the cartridge housing receptacle on the antenna and push the housing into the receptacle until it snaps into place. See Figure 4.

Fig. 4

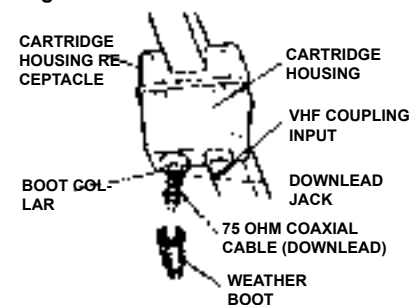

STEP 6. Attach the 75 ohm coaxial cable to the "downlead" connection on the cartridge housing. Slide weather boot over connectors and boot collar. See Figure 4.

STEP 7. To mount the antenna on the mast, loosen the nuts on the mast clamp(s). Slide antenna booms and braces and clamps over the mast and tighten securely so they are parallel. See Figure 5.

Fig. 5

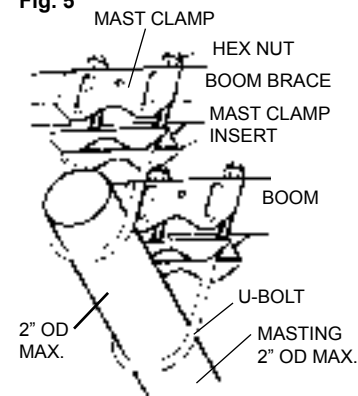

STEP 8. The 75 ohm coaxial cable downlead may be secured to the mast by taping or the use of plastic wire ties.

HOW TO PROVIDE LIGHTNING PROTECTION FOR TV ANTENNA AND SET

Step 1. Mount the lightning arrestor or 75 ohm grounding block as close as possible to where the 75 ohm coaxial cable downlead enters the house. See Fig. 6.

Fig. 6

Example of antenna grounding as per National Electrical Code, ANSI/NFPA 70

Step 2. The ground wires for both the mast and the downlead should be copper or aluminum wire, number eight (8) or larger. See Figure 6.

Step 3. The downlead wire from the antenna to the grounding block and the mast ground wire should be secured to the house with stand-off insulators, spaced from four (4) to six (6) feet apart. See Figure 6.

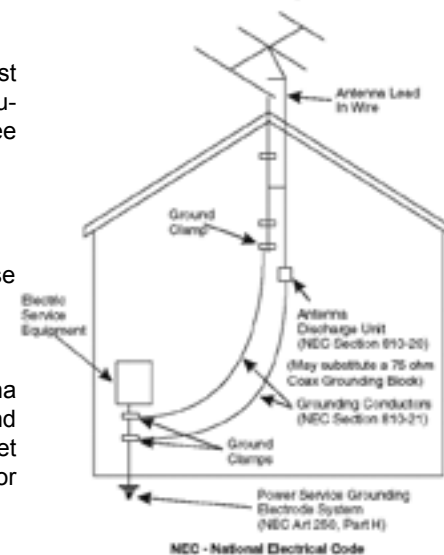

NOTE: In the case of a "ground up" antenna installation, it may not be necessary to ground the mast if the mast extends four or more feet into the earth. Consult a TV serviceman for the proper depth in your location.