



Rack Mount High-Power EDFA
Installation Guide

OTEA-CL Series

Notices

The information contained in this document is subject to change and revision without notice. Olson Technology, Inc. (OT) believes that the information provided is accurate and reliable, however OT makes no warranty of any kind as to the information contained in this document, including without limitation the implied warranties of merchantability or fitness for a particular purpose. Further, OT does not assume responsibility for use of the information contained in this document or for any infringement of patents or other rights of third parties that may result from its use. OT shall not be liable for errors contained in this document or for incidental or consequential damages in connection with the furnishing, performance, or use of this material.

OT grants no license, directly or indirectly, under any patent or other intellectual property rights from use of the information provided herein.

Copyright 2007 Olson Technology, Inc. All rights reserved. You may not reproduce, transmit, store in a retrieval system, or adapt this publication, in any form or by any means, without the prior written permission of OT, except as allowed under applicable copyright laws.

Preface

Please take time to read and understand this User's Guide and familiarize yourself with the information that we have compiled for you before you use the product. This User's Guide should stay with the product to provide you and all future users and owners of the product with important operating, safety and other information.

Table of Contents

1. PRODUCT FAMILIES.....	1	4. INSTALLATION PROCEDURE.....	12
KEY FEATURES.....	1	OVERVIEW.....	12
OTEA RACK MOUNT DEVICES.....	1	THE FRONT PANEL OF THE UNIT.....	13
2. SAFETY INFORMATION.....	2	REAR PANEL OF THE UNIT.....	15
SAFETY CONVENTIONS.....	2	RECOMMENDED INSTALLATION EQUIPMENT.....	16
LASER CLASSIFICATION IIIb > 100MW 1550NM.....	3	MECHANICAL MOUNTING.....	18
DEVICE SAFETY LABELING.....	4	ELECTRICAL CONNECTIONS.....	19
GENERAL SAFETY INSTRUCTIONS.....	5	OPTICAL CONNECTIONS.....	21
CONNECTOR CLEANING GUIDE.....	7	INITIAL ELECTRICAL POWER-UP AND CONFIGURATION.....	26
PROTECTING YOUR DEVICE FROM OPTICAL CONNECTOR DAMAGE.....	9	ENABLING OPTICAL AMPLIFICATION.....	29
BACK REFLECTION PREVENTION.....	10	5. TROUBLESHOOTING.....	30
3. ENVIRONMENT AND PRECAUTIONS.....	11	LED STATUS INDICATION.....	33
		RS-232 INTERFACE COMMANDS.....	34
		RS-232 PROVISIONER COMMANDS.....	36

1. Product Families

Olson Technology, Inc. manufactures high performance fiber amplifiers and lasers, modules and subsystems to meet the rapidly growing demands of the communication market. OT's wide range of high and low power amplifiers and lasers are compact, cost-effective and exceptionally reliable.

OT's product innovation stems in part from a concept known as parallel pumping which enables fiber devices to generate almost unlimited power and provides for pumping redundancy, enhanced reliability and extended lifetime of devices.

Key Features

- ***Long life time***
- ***Low noise figure***
- ***High conversion efficiency and low power consumption***
- ***Unique saturated output power***
- ***Compact design***
- ***Low PMD and PDL***

OTEA Rack Mount Devices



The OTEA devices are rack mount amplifiers designed for use in standard 19-inch equipment racks. They are complete with dual universal voltage/frequency power supplies for redundancy. The unit is controlled through menu driven front pushbuttons with an LCD display or a standard RS-232 interface.

2. Safety Information

Safety Conventions

We use various words and symbols that are designed to call your attention to hazards or important information. These include:

WARNING:  

Refers to a potential *personnel* hazard. ( *Electrical*) ( *Laser radiation*) It requires a procedure that, if not correctly followed, may result in bodily harm to you and/or others. Do not proceed beyond the **WARNING** sign until you completely understand and meet the required conditions.

CAUTION: 

Refers to a potential *product* hazard. It requires a procedure that, if not correctly followed, may result in damage or destruction to the product or components. Do not proceed beyond the **CAUTION** sign until you completely understand and meet the required conditions.

IMPORTANT

Refers to any information regarding the operation of the product. Please do not overlook this information.

Laser Classification IIIb > 100mW 1550nm

This device is classified as a high power **Class IIIb** laser instrument under 21 CFR 1040.10. This product emits invisible laser radiation at or around a wavelength of **1550 nm**, and the total light energy radiated from any optical output is greater than **100mW**. This level of light may cause damage to the eye and skin. Despite the radiation being invisible, the beam may cause irreversible damage to the cornea. Laser safety eyewear is not provided with this instrument, but must be worn at all times while the laser is operational.

WARNING:



Use appropriate laser safety eyewear when operating this device. The selection of appropriate laser safety eyewear requires the end user to accurately identify the range of wavelengths emitted from this product. If the device is a tunable laser or Raman product, it emits light over a range of wavelengths and the end user should confirm the laser safety eyewear used protects against light emitted by the device over its entire range of wavelengths.

WARNING:



Use of controls or adjustments or performance of procedures other than those set forth in this User's Guide may result in hazardous radiation exposure.

CAUTION:



Do not install or terminate fibers when amplifier is active.

Device Safety Labeling

The figures below show the FDA, and other labels and their placement on the product.

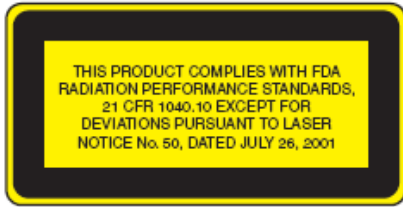

Certification Label

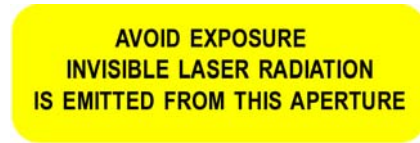

Aperture Label



Warning Logotype
Location

Top Cover or Front Panel
of Device.

General Safety Instructions

In order to ensure the safe operation and optimal performance of the product, please follow these warnings and cautions in addition to the other information contained elsewhere in this document.

CAUTION: 

Before supplying the power to the instrument, make sure the correct voltage is used. Failure to use the correct voltage could cause damage to the instrument.

WARNING: 

Make sure this instrument is properly grounded. Any interruption of the protective grounding conductor from the protective earth terminal can result in personal injury.

WARNING: 

This device and all parts or components thereof are not meant to be operator serviced, except for the replaceable fuse(s). Refer all servicing to qualified OT personnel. To prevent electrical shock, do not remove covers or system components. Any tampering with or disassembly of the device, parts, or components will void the warranty and possibly expose the operator to an electrical shock hazard.

WARNING: 

DC powered instruments are not meant to be attached to a power source that is capable of delivering more than 30 Amps or connected to a circuit with a 30 Amp breaker. Failure to limit the source current to less than 30 Amps can result in operator injury, voiding of the warranty and/or instrument damage.

WARNING: 

Laser radiation is emitted from all optical outputs simultaneously. Avoid exposure from all unused optical ports.

WARNING: 

Do not enable the laser when no fiber or equivalent is attached to the optical output connector.

WARNING:

If this instrument is used in a manner not specified in this document, the protection provided by the instrument may be impaired and the warranty will be voided. This product must be used only in normal conditions.

Connector Cleaning Guide

Optical fiber connectors require care and careful cleaning. Caps should be left on connectors whenever they are not in use. Do not touch the connector end. Damage to connector end faces caused by improper care is not covered by the warranty.

Equipment We have found the following equipment useful in maintaining connector cleanliness:

Automatic connector cleaner (CLETOP™) (available from most suppliers) or canned isopropyl alcohol with clean optical wipes and canned air.

Connector inspection microscope. (The Noyes 300-200 optical fiber scope is good, as is the AMP fiber inspection scope and the Buehler fiber scope. Typical low cost multi-mode connector viewers are not suitable for inspecting single mode connectors).

Cleaning procedure

WARNING: 

After making sure that the light source is off (!), check the connector ferule end using the connector inspection microscope. If no dirt, grease or small particles are visible no further cleaning is necessary.

Use canned air to remove loose particles.

Either Use automatic connector cleaner such as "CLETOP™." Wipe the connector as directed on the box. Be careful with angled connectors (connectors with green boots) to make sure the full surface contacts the cloth. You will need to tilt the connector slightly. Using an automatic cleaner is our preferred technique. Note that some low cost cleaners may leave small particles on the fiber surface.

Or Moisten a clean optical wipe with alcohol and wipe connector. Finish by wiping the connector with a dry part of the wipe. Be careful not to allow oil from fingers to contact connector. Allow the connector to dry for 1 minute. Inadequate drying can result in the alcohol residue burning into the connector end when the fiber is lit.

Inspect the connector ferule under the microscope. Clean again if necessary.

If a connector is to be used to transmit high powers (>50mW), great care should be taken in cleaning. Mating loss of these connectors should be kept to a minimum.

Bulkhead cleaning

Fiber bulkhead adapters contain a zirconia or phosphor-bronze sleeve. After removing the connectors, these can be cleaned with a pipe cleaner moistened with isopropyl alcohol, and dried with canned air.

Troubleshooting

A small black area appears in the middle of the connector which cannot be removed by cleaning.

Some material (typically oil from skin contact, residue alcohol or particles from connector cleaning devices) has burnt on the connector surface. Do not use your device and contact OT for assistance.

A small circle of dried droplets are visible on the end of the connector.

The connectors were mated when one was still wet (typically from water/alcohol). Repeat cleaning procedure.

The connector is clean but the loss on mating varies by 10dB or more.

Check to see if the bulkhead adapter sleeve is cracked. Be careful not to over-tighten connectors.

A gray powdery grime continues to appear on the connectors after repeated mating.

If the bulkhead adapter sleeve is made from phosphor-bronze, some of the metal is probably rubbing off on the connectors.

Protecting Your Device from Optical Connector Damage

Output powers of 1 Watt or less

CAUTION: 

High optical powers can burn oil from fingerprints, dirt, dust or cleaning alcohol into the connector ends. The resulting damage looks like a black dot in the middle of the connector end-face and is clearly visible under a connector viewer microscope. If you are using an amplifier for component testing, we recommend following the "Connector cleaning guide" section (above).

If connectors are being frequently connected and disconnected, occasional connector contamination is likely. Large numbers of connector mating are common in a manufacturing setting where hundreds of parts are being power tested.

Back Reflection Prevention

CAUTION: 

Back reflection into the amplifier or laser can degrade the device performance or cause failure. The device is designed to accommodate normal back reflections exhibited from use with fiber spans.

For outputs with standard fiber connectors, examples of normal back reflection are as follows. Expected back reflection for FC/PC connectors is -14dB. Expected back reflection for FC/APC is -40dB. Proper cleaning of the connectors is an essential process for successful use of the device. We recommend following the attached "Connector cleaning guide".

For bare fiber outputs, the expected back reflection with a flat cleave is -14dB. A random break or crushed fiber may have any back reflection from -14dB and lower. When correctly splicing to a similar fiber, the splice has a back reflection around -60 dB. It is essential to have a quality cleave and fusion splice by a trained individual to minimize the risk of inducing excessive back reflection. Splicing the bare fiber output to a dissimilar fiber can cause excessive back reflection and will void the warranty. Contact the manufacturer if this process is required. If the bare fiber will be powered up without being spliced to another fiber, make sure the surface of the fiber is of good quality and clean. Check the quality of the cleave at a low output power using an infrared visualizer and increase the output power.

Optical damage may result from failure to comply with the above instructions. Such damage is not covered by the warranty.

3. Environment and Precautions

WARNING: 

Always use your device in conjunction with properly grounded power source.

CAUTION: 

Do not expose the device to a high moisture environment.

CAUTION: 

The amplifier has protection against a low optical input signal and the unit will shut down if the input signal is removed. We recommend the amplifier not be used without an optical input signal. OT will not be responsible for the damage sustained by the device resulting from a lack of input signal.

CAUTION: 

Avoid unnecessary back reflections into the amplifier otherwise the device may be destroyed. Use caution when connecting the amplifier to an external fiber line. Strong non-linear effects may turn a significant portion of optical power into the amplifier.

CAUTION: 

Wait at least 2 minutes after switching on the device before enabling maximum emission.

CAUTION: 

Always clean optical connectors before connecting them to the amplifier. Use only the type of connectors noted in the specification. Use special high precision adapters for connecting the amplifier to an input source, otherwise maximum polarization extinction ratio may not be achieved. OT will not be responsible for any damage sustained by the device as a result of using dirty or incompatible connectors.

4. Installation Procedure

Overview

This guide is intended to aid a technician or operator in the field with installation and troubleshooting during the installation process. The troubleshooting section is intended to help determine the cause of any fault, whether it be with the EDFA or some other component in the network and to determine whether the failure is caused by some configuration error or faulty connection to the EDFA. Although the technicians may be well versed in troubleshooting techniques, they may not be aware of the specific features of the OT EDFA that can aid in this process.

Specific installation procedures are also found in the operations manual. However, this guide covers installation and troubleshooting in more detail in an effort to aid the installer further and for additional reference as needed.

It is assumed the technician is properly trained to handle fiber optics and laser class IIIb optical equipment.

The Front Panel of the Unit

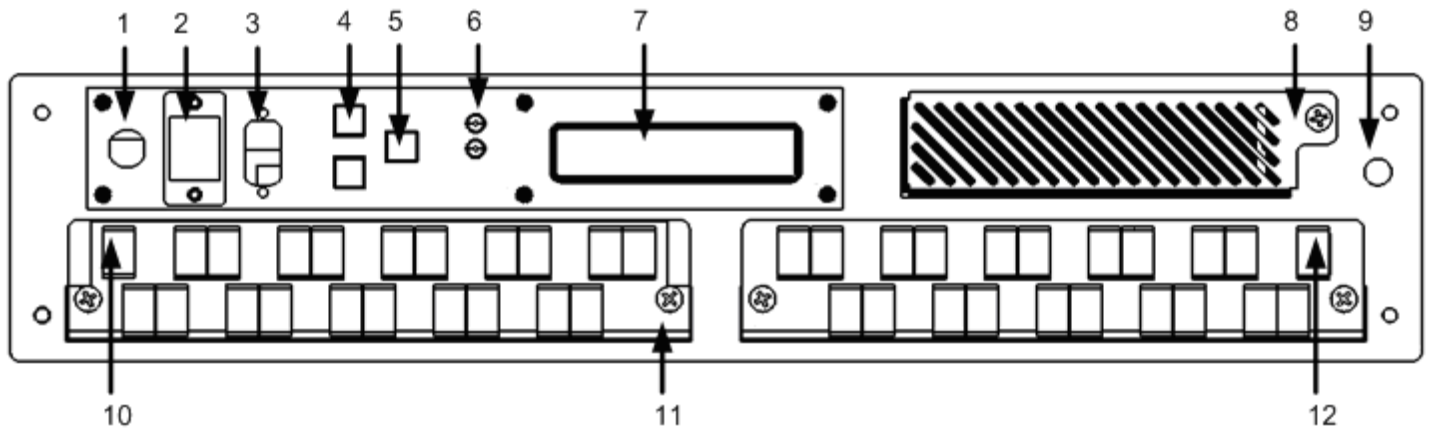

The actual appearance of the front panel is determined by the specific model of the EDFA.

1. Laser emission key-switch
2. 10/100BaseT LAN (Ethernet) port for SNMP and other TCP/IP communication protocols.
3. RS-232 serial craft port interface.
4. (Optional) LCD menu selection buttons.
5. Low power mode button.
6. Alarm state indication LED's.
 - Green = no alarm
 - Yellow = minor alarm
 - Red = major alarm.
 - i. 48V SUP = 48V electrical power supply status
 - ii. PWR IN = Optical (1550nm) input power status
 - iii. PUMP = Internal laser pump diodes status
 - iv. MODE = Equipment mode status
 - v. EQUIP = Equipment overall status
 - vi. PWR OUT = Optical (1550nm) output power status
 - vii. FANS = Equipment fan status
7. (Optional) LCD display.

8. Front air intake opening. Cover guard is removable with thumb screw to allow access to filter material for service/ replacement.
9. Grounding point.
10. Optical (1550nm) output monitor port.
11. Fiber tray with thumb release screws for internal optical connector access/servicing.
12. Optical (1550nm) input port.

Rear Panel of the Unit

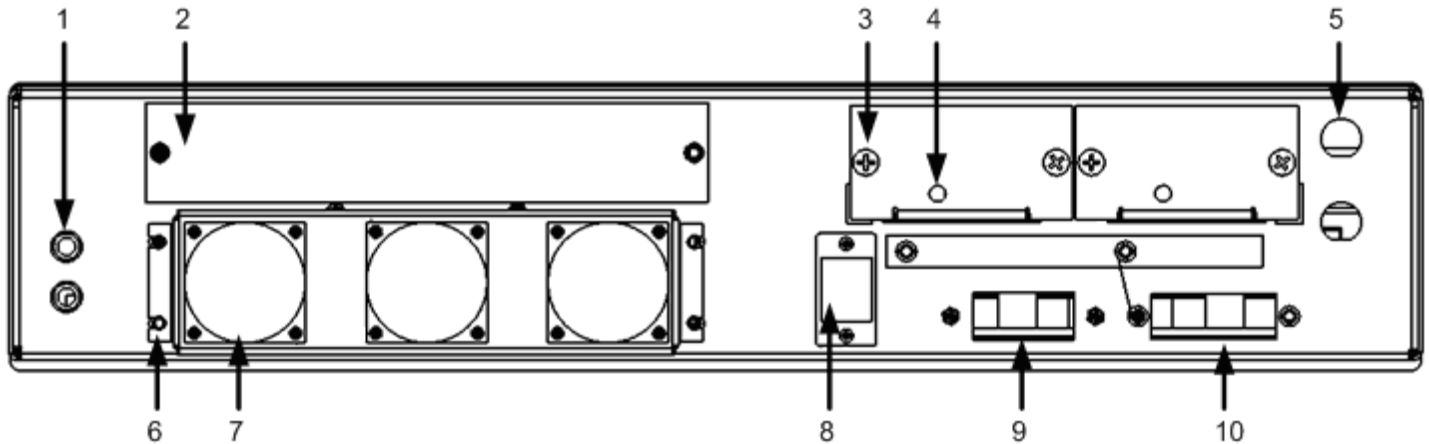

1. Case grounding points.
2. Expansion panel for future use.
3. Removable power supply card with thumb screws
4. Power supply card status LED
 - a. GREEN LED indicates normal operation.
 - b. No illumination of LED indicates power failure.
5. Fuse holders
6. Fan shroud with securing screws
7. Fans (air flow through front of unit and out through fans at rear of unit)
8. RJ45 socket with alarm relay connections.
9. Electrical signaling terminal strip
 - a. DET1, DET2, SIG1, SIG2 for future use
 - b. INT, INT are interlock terminals. They should be electrically shorted together to enable operation of the unit. They may be wired to an external interlock switch if required.
10. External power supply terminal strip
 - a. RTN (A), -48V (A), RTN (B), -48V (B) for redundant external -48V return and supply.

Recommended Installation Equipment

The following is a list of suggested equipment to aide installation and troubleshooting; it may not be complete due to unique requirements at different locations.

1. Handheld Optical Power Meter with specifications:
 - Capable of handling up to +23dBm at 1550nm. (Verify power requirement against optical output power specification for the device being installed)
 - Most power meters have wavelength selection, but solely for correct calibrated reading not to actively filter out that wavelength range. That means that if both video (1550nm) and data (1310/1490nm) are both being transmitted down the same fiber the meter will display the composite power level. There are newer more advanced optical power meter types that include wavelength specific filters for use in diagnostic of optical CATV systems to avoid this issue. These meters can help simplify power measurements but are not strictly required.
2. Optical connector end-face inspection scope with angled and flat adapters for the connectors used on the amplifier device (typically SC, but check the specification document for connector types used). It is recommended that a non-direct viewer is used so that the end face is not directly observed by eye, instead by a digital sensor.
3. Optical fiber end-face cleaning supplies (isopropyl alcohol, lint free optical wipes, cleaning cartridges (such as a CLETOP™)).
4. Laptop with Ethernet and RS-232 Serial port communication capabilities and serial terminal software (such as “HyperTerm”).
5. RS-232 serial cable(s) - mating type and straight/cross-over determines if serial communication can occur. See specification manual for pin out of device serial port.
6. Multiple SMF-28 fiber patch cords (with 3mm buffering preferable) of types:
 - SC/APC to SC/UPC
 - SC/APC to SC/APC
 - SC/UPC to FC/PC*
 - SC/APC to FC/PC*

* FC/PC is a common connector type on optical test equipment and instruments such as optical power meters and optical spectrum analyzers.

7. Optical connector adapters, allowing mating of the various optical patch cords above.
8. Ethernet cables and hub/switch to allow device to be accessed via SNMP.
9. Variable Optical Attenuator (VOA) - useful for optical diagnostics.
10. An OSA (Optical Spectrum Analyzer) is not normally required but helpful in isolating some optical issues.
11. Mechanical mounting equipment - Screw drivers, bolts, etc.
12. Electrical installation equipment - multimeter, electrical power cabling, electrical cable termination tools, etc.

Mechanical Mounting

1. Determine mounting location:
 - a. The unit will fit in a standard 2RU 19-inch rack space with the use of the (supplied) 19" mounting brackets.
 - b. The fans in the device direct airflow through the intake filter on the unit front panel and expel air from the fans at the rear. Allow enough clearance around the front filter and rear fans for good airflow. Do not allow foreign objects into any of the air ducts and do not block them with electrical or optical cables.
 - c. **Caution:** Take care during installation not to damage the unit. Special attention should be given to the optical connector adapters on the front panel and electrical terminals on the rear panel.
2. There are two 19" mounting brackets with mounting screws supplied. If the brackets are not already attached to the unit they should be first bolted to the unit before installation in the rack.
3. One of the mechanical features of the EDFA is the fiber trays in the front of the unit. These trays allow for the installer or maintenance person to access and unplug the internal fiber connector from the optical connector adapters for inspection and cleaning. Before relocating the unit to the rack, make sure the trays are secured in the closed position via their thumb screws.
4. Mount the EDFA to the rack using the screws required by the equipment rack at the installation site. See the unit's specification document for weight and dimensions.
5. Once the unit is mounted make sure the laser emission key-switch on the front panel is in the off position. The next step is to hook up the electrical wiring as specified in the next section.

Electrical Connections

1. **Caution:** Ensure the laser emission key-switch is in the off position (or removed) before electrical turn-up.
2. Information on the electrical systems of the unit:
 - a. The unit has two power supply cards which are accessible from the rear panel. These power supplies are redundant, so a single failure will allow the unit to continue its operation but with appropriate warning alarms. The power supply cards are also hot swappable. There is no electrical power switch for the unit. Removing both power supply cards at the same time will power down the unit. It is suggested that the cards remain plugged in during the installation and that the power feeds be switched off until ready to turn unit on for the first time.
 - b. There is a laser emission key-switch on the front panel that turns the output optical power of the unit off/on. This should always remain in the off position for laser safety until the unit is completely hooked up and ready for testing. Be certain it is in the off position at this time.
 - c. There are fuse holders on the rear panel of the unit. Ensure they contain the correct rated fuse (see specification document for the unit). These should only require access during normal operation to replace a blown fuse.
3. The two Interlock electrical terminals on rear panel (both marked INT) require shorting together for the EDFA to operate normally. This interlock feature is provided for laser safety purposes as required by certain installations e.g. for an external laser interlock switch on a cabinet or room door.
4. Electrical power connections. In this step the external electrical power supply(s) will be connected to the terminal strip on the rear of the unit. It should be noted that if the electrical supply is on then the unit will immediately power up as soon as the first circuit is completed.
 - a. Always connect the ground terminal cabling to the unit first (and during any un-install of the unit remove them last).
 - b. Next connect the $-48V_{DC}$ and supply return terminals to the external power supply. See the specification document for the unit's current requirement. Use the correct gauge wire for the current requirement and the correct buffering material for the supply voltage.
5. To take full advantage of the power supply card redundancy it is advised that two different external power sources are used.

6. The unit should be powered up at this point. The fans will be spinning and front panel LED's will be illuminated. The power supply LED's on the rear of the unit should both be green. The laser emission key-switch should remain in the off position.
7. If the unit will be connected to a wired network LAN then the Ethernet cable should be connected to the Ethernet port on the front of unit at this time and routed to an appropriate networking hub or switch.
8. If required an RS-232 cable may be connected to the serial port on the front panel of the unit.
 - a. The RS-232 interface has been set to the following parameters:
9600 Baud, 8 data bits, 1 stop bit, no parity and no flow control.
 - b. A three wire (RxD, TxD, GND) interface is used. In addition, the interface cable must have the proper connector on each end. Cables typically have 9 pins (DB-9) or 25 pins (DB-25) with "male" pins or "female" receptacles inside the connector shell. The RS-232 connector on the front panel of the Laser Driver is a 9 pin (DB-9) female connector. Therefore the users' interface cable must have a 9 pin male (DB-9) connector on one end to connect to the laser driver. The other end of this cable needs to match the computers' interface connector. Remember that this cable must be wired in a straight-through configuration. Therefore, on a computer connection with a 9-pin DB-9 connector Pin 2 would connect to Pin 2, Pin 3 to Pin 3 and Pin 5 to Pin 5.

Optical Connections

1. Installer Must Be Trained in (Class IIIb) Laser Safety.

2. Prior to connecting any fibers to the EDFA a quick review on fiber handling and how it relates to potential problems and more importantly safety are in order:

c. Review the optical safety guidelines at the start of this guide.

d. The EDFA's covered in this guide are assumed to be class IIIb as described in IEC 60825-1.2 Standards. Although there are several factors that influence the class rating, the optical output power level is the main factor and is what ultimately may cause harm if appropriate precautions are not followed.

e. A few precautions are listed below but should not be used in place of full training;

- i. Do not examine or look directly into broken, severed, or disconnected optical fibers or cables. This includes optical connectors where there is no dust-cap in place.
- ii. Do not crush, compress, bend excessively, walk on or have over 10-lbs of cable weight placed on external optical cables (that have a minimum of 3mm protective buffering).
- iii. If there are optical connectors where dust-caps have been removed and no fiber connected, it is important to place dust caps on these connectors immediately. If power is off it is still important to keep dust off the connector.
- iv. Do not touch the optical connector end-face.
- v. Dirty optical connectors can result in permanent damage to the fiber end-face once optical power is applied. In these cases of optical damage, cleaning will not remove the burnt-on matter and the optical output power will be reduced. The connector will require replacement to operate at nominal performance.
- vi. It is the installer's responsibility to be sure all connections are clean before applying optical power (i.e. enabling laser emission).
- vii. Dirt includes oil from an accidental quick touch of a finger tip, or dirt from the air after exposure for even a short length of time.
- viii. Cleaning of the fiber end-face while optical output power is being emitted will also cause burn damage to the end-face and should be avoided.

- ix. Optical connectors can also have pits and cracks in them from mechanical mistreatment or by mating connectors that have dirt/contaminants on the end-face(s). Cracks or pitting in the central location of the fiber end-face reduce optical output power and, the connector will require replacement to operate at nominal performance. Dirt that gets into the pits and cracks will remain and the connector will need to be replaced.

3. Optical Inspection and cleaning of fiber connector end-faces:

- a. **Warning: Make sure the laser emission key-switch is in the off position**
- b. The optical connector adapters of the unit have built in, spring loaded, shutters. Not only do these shutters help prevent exposure to laser light, they also help prevent contamination by airborne dirt to the internal connector optical end-faces. In addition the internal optical connector end-faces are inspected and cleaned at the factory before shipping. If any of the optical connector adapters are missing external shutters then it is important to replace the adapters as soon as possible with shuttered compatibles. A short term solution is place a dust-cap on the adapter if not in use.
- c. Any external optical cable to be connected to an adapter on the unit should first be inspected just before connecting (but first ensuring it is not transmitting unsafe optical power levels). It is also advisable to inspect the internal connector end face at this time. If a dirty fiber end-face is mated with a (clean) one, then typically both will become contaminated. In addition, both could be damaged if optical power is restored.
- d. Cleaning procedure for optical fiber connectors and adapters
 - i. Connector End-face Cleaning Methods (after cleaning re-inspect)
 - 1. **Preferred Method:** Using a cleaning cartridge such as a “CLETOP™” device; wipe the connector end-face as directed on the device. Be careful when cleaning angle-polished optical connectors (typically marked with a green boot) to make sure the end-face is in full contact with the cleaning cloth, which may require you to tilt the optical connector slightly.
 - 2. Moisten a clean, lint free, optical wipe with alcohol and wipe connector. Finish by wiping the connector with a dry part of the wipe. Over use of cleaning alcohol and/or inadequate drying can result in the alcohol residue on the fiber end-face. Inspect after cleaning for liquid drying patterns. If they exist, then connector must be cleaned further to remove them.
 - 3. Use canned air to remove loose particles.

- ii. Internal optical connectors of the unit may also be inspected and cleaned. The trays which house the connectors can be slid part way out after loosening the thumb screws. The internal connectors are plugged into the optical connector adapters and can be pulled out from the rear. Gently pull out the adapter, by the body of the connector (never the fiber or the boot) that needs inspection or cleaning. It can then be cleaned by the normal cleaning procedures. Be sure to correctly re-mate the optical connectors to the adapters.
- e. Description of EDFA optical connector types.
- Depending on which unit type is to be installed there may be one or more optical connector types to address, the actual connector types may differ from the ones detailed here due to specific customization of the units at the customers request:
- i. The regular (non-CWDM) version of the multi-port EDFA uses SC/APC (green/angled) optical connectors exclusively.
 - ii. The CWDM version of the multi-port EDFA uses both SC/APC (green/angled) and SC/UPC (blue/flat) optical connectors.
 - iii. The APC stands for Angled Polished Connector which has an optical end-face cut/polished to be 8° with respect to the direction of the fiber. The connector bodies are typically green in color.
 - iv. The (U)PC stands for (Ultra)-Polished Connector which has an optical end face cut/polished to be 90° with respect to the direction of the fiber. The connector bodies are typically blue or black in color.
 - v. The blue and green are visual aids to remind end user that the two types are different.
 - vi. **Caution:** Do not mate an angled (APC) connector with a flat (UPC or PC) connector. This can cause mechanical damage to both connectors and does not provide correct low loss optical mating. At a minimum there will be an “air gap” between the two connector end-faces causing large attenuation (loss) of the optical power. It can also cause damage to connectors by scratching or cracking the flat connector with the tip of the angled connector. It is acceptable to mate a flat Polished (PC) and ultra-polished (UPC) connector since the difference is related to manufacturing quality, not physical end-face angle. However, to minimize optical attenuation it is advisable to not use the lower grade (PC) connectors.
 - vii. All the connector types (e.g. SC, FC, LC, E2000) have some kind of alignment key or pin, which only allows one orientation for connector-to-adaptor mating, however this does not prevent mixing of angle and flat polish connector types.

- viii. **Caution:** Ensure a correct mate between optical connectors - It is outside the scope of this manual to cover all the details of optical connector and adapter types and how to actually align and ensure correct mate. This should be covered in the operators/field engineer's optical training. More information on connector and adapter types and their use may be found from manufacturers such as e.g. Molex, Huber Suhner, Seiko, ADC.

4. Connecting external optical cables to the unit.

- i. **Caution:** Clean and inspect all optical connectors (internal and external) as detailed above and follow laser safety procedures.
- ii. **For CWDM EDFA Models.** There is no specific order to initial optical hookup but if the unit is a CWDM model then it is suggested to hook up the Voice/Data ports first (OS ports). These are designated by blue or black optical connector adapters housing the internal SC/UPC blue or black optical connectors.
 - i. The CWDM ports (OS Ports) are for routing the Voice and Data digital optical signals carried upstream and downstream (bi-directional) on 1310nm (O-Band) and 1490nm (S-Band) optical wavelengths respectively. These signals are multiplexed with the 1550nm (C-band) optically amplified output video signal from the corresponding OSC port (angled/Green connector) The OS to OSC port multiplexing is passive and the Voice/Data routing/communication should be independent of the operational state of the EDFA unit.
 - ii. Connect SC/UPC jumpers between the required CWDM OS port and the installation sites voice/data equipment. **Caution:** Do not attempt to mate angled connectors to these OS CWDM ports.
 - iii. That the voice/data does not rely on any electronics in the EDFA means that some testing can take place immediately after hooking up the data before powering up the EDFA and before the Video hookup. With EDFA optical amplification disabled (laser emission key-switch off) the OS to OSC port loss for 1310nm and 1490nm can be easily checked/verified for optical continuity and loss. See the specification document for maximum specified loss at these wavelengths.
 - iv. Next connect the Output OSC ports (SC/APC/Green) to the installation site downstream fibers (to the premise).
 - v. At this stage the data/voice service could be tested as there should be optical continuity from installations sites voice/data equipment to the premises. The advantage of checking at this stage is that it is easier to

isolate any problems of the deployment that are not related to video equipment and/or the EDFA's active optical performance.

iii. For non-CWDM EDFA models

- i. Next connect the Output C ports (SC/APC/Green) to the installation site downstream fibers (to the premise).

iv. For all EDFA Models: Once all CWDM and output port connections have been made then:

- i. Connect the installation sites 1550nm (C-Band) video feed to the (SC/APC/Green) Input C port of the EDFA unit.
 - ii. (Optionally) Connect monitoring equipment (power meter, CATV detector) to the 1550nm (C-Band) amplifier output monitor port of the EDFA unit. See specification document for monitor port output power (typically much lower output power level than the main output ports).
- v. Proceed to next section

Initial Electrical Power-Up and Configuration

1. **Installer Must Be Trained in (Class IIIb) Laser Safety.**

2. **Caution:** Ensure the laser emission key-switch is in the off position (or removed) before electrical turn-up.

3. Electrical turn Up:

- a. Enable $-48V_{DC}$ electrical power to the unit. (see electrical connections section above)
- b. Ensure the power supply cards are fully inserted in the rear of the unit.
- c. Front panel LED's will go through initial illumination cycle of indication colors (allow 10 seconds)
- d. Front panel LED's will indicate unit status after power up cycle.
- e. Allow 1-2 minutes for LAN/SNMP service to be active after initial power up.
- f. If the optical video input signal is at the correct operating level the Input Power LED on the front panel should be green. (see LED troubleshooting table below)

4. Communicating over RS-232 to units craft port.

- a. Ensure correct serial cable pin out and gender is used and both ends are fully mated on the unit and the PC.
- b. Any serial communication "terminal" software may be used. "HyperTerm" is one such program.
- c. Key settings to be aware of for communication is as follows:
 - i. Serial Port - The port number of the PC where the serial cable is connected.
 - ii. 9600 Baud
 - iii. No Flow Control
 - iv. 8 bits data
 - v. Parity None
 - vi. Stop Bits 1.

- d. Recommended Additional settings:
- i. Echo Typed Character Locally
 - ii. Send line Ends with Line Feeds
 - iii. Append Line Feeds to Incoming Line Ends.
- e. If the terminal software is correctly set up then the unit will respond with a prompt
>
if the <Enter> key is pressed on the PC.
- f. Consult the Operations manual for full list of applicable serial commands.
- g. **Example:** Checking optical input power level via serial terminal software:
- i. Enter the text:
RI P<Enter>
 - ii. The unit will respond with text similar to:
>I nput Power = 6.2 dBm
Which in this case reports that the input power is 6.2 dBm (4.2 mW).
- h. It is important to correctly configure the TCP/IP settings of the unit, via the serial interface, for correct operation on the installation site LAN for SNMP communication.
- i. Login to gain access to provisioning commands:
LOGI N 999999<Enter>
where 999999 is the default login password, actual password may have been changed by operators. Note: if you do not login then you can still read settings but will not be able to change/write provisioning settings.
 - ii. Set fixed TCP/IP address of unit
SI P xxx. xxx. xxx. xxx<Enter>
where xxx.xxx.xxx.xxx is the fixed TCP/IP address that has been designated for this unit at this installation site.
 - iii. Set the TCP/IP Gateway address that the unit may use
SGATE yyy. yyy. yyy. yyy. yyy<Enter>
where yyy.yyy.yyy.yyy.yyy is the fixed TCP/IP address that has been designated as the gateway for the unit at this installation site.
 - iv. Set the TCP/IP subnet mask the unit
SNET zzz. zzz. zzz. zzz <Enter>
where zzz.zzz.zzz.zzz is the TCP/IP sub-net mask that has been designated for the unit at this installation site.

- v. The present IP settings can be reported using the commands `GI P`, `GNET`, `GGATE`.
- i. Verify output power settings
 - i. To verify the per-port output power set-point
`RPS<Enter>`
This will return the set-point of the per-port output power.
 - ii. If the set-point is not correct use the command
`SOP xx. x<Enter>`
to change the output power set-point where `xx.x` is the desired per-port power in units of dBm. See the unit specifications for the allowable per-port output power range that is user settable.
 - iii. To verify the actual per-port output power use the command
`ROP<Enter>`
which will return the per-port output power as measured by the unit's internal power monitor.
 - iv. **Note:** If the laser emission key-switch is off or the unit is in major alarm then the EDFA will emit amplified optical power so the actual measured optical output power (reported by the `ROP` command) will be very low and not in agreement with the user output power set point (reported by `RPS`). This is normal, once the amplifier/laser emission is enabled the two values will be in agreement.
 - v. **Note:** The amplifier output ports are passively split and have an associated range of output powers. See Test Data provided with shipping docs for measured port-to-port power variation.
 - vi. **Note:** The maximum user settable per-port optical output power is reported in dBm by using the command
`RMP<Enter>`

5. With the above items completed the EDFA may be activated by enabling laser emission.

Enabling Optical Amplification

1. **Enable the EDFA optical operation by turning the laser emission key-switch to the ON position. Allow 10 seconds for the unit to reach steady state. The Mode LED light should turn Green and Output Power LED should turn Green.**
2. Use the ROP command to read monitored per-port optical output power.
3. With the EDFA active the input ~1550nm should now be amplified to the premise locations and associated testing can be performed.
4. **Note:** The optical output monitor port may be used to check ~1550nm service,
5. Further adjustment of the per-port output power may be made while the EDFA is active (using the SOP command) to maximize quality of service.
6. **Note:** With the EDFA inactive (laser emission key-switch off or major alarm state in the unit) there is no ~1550nm amplified signal emitted from the output ports or monitor port.
7. **Note:** Turning the laser emission key-switch to the OFF position will cause an output alarm and an equipment alarm condition on the unit. That is normal.
8. **Note:** With CWDM models the signal power of ~1310nm and ~1490 data through the OS and OC ports is not affected by laser enable state.

5. Troubleshooting

1. **Troubleshooting personnel must be trained in (Class IIIb) laser safety.**
2. **Caution: follow laser safety procedures at all times.**
3. **Caution: follow correct fiber handling and cleaning procedures (see above).**
4. **NOTE:** It can not be stressed enough that the most common causes of equipment alarm, or poor quality of service is due to incorrect optical fiber connector mating and poor optical fiber connector end face cleanliness. In general whenever a problem is located at a specific port, the Technician should first verify that the connection type is correct for that mate location and that both fiber end-faces of the mate are clean.

5. Electrical issues:

- a. If no LED illumination on front panel of unit:
 - i. Check polarity and voltage of external power supply to rear panel electrical power terminal strip
 - ii. Check power supply cards are installed correctly
 - iii. Check fuses for continuity
- b. -48V status LED in major or minor state
 - i. If unit is operating but one of the power supply cards does not have green status LED illumination
 1. Check power supply card for physical damage/replace power supply card.
 2. Check that the power supply card is completely inserted.
 - ii. If Unit is operating and both of the power supply cards have illuminated green status LED's.
 1. Check fuses for continuity.
- c. Fan alarm in major or minor state
 - i. This indicates that one or more of the fans mounted to the rear of the unit are not operating within specified rotational speed range.
 - ii. Replace any fans that are stopped or rotating slowly or making abnormally loud operating noise.

- iii. Also If the unit has been in operation prior to the current alarm condition inspect service (replace) the air filter material on the front panel of the unit to prevent restriction of air flow due to dust build up.
- iv. Ensure no air vents or ducts or fans are blocked or obscured by foreign objects, optical or electrical cables.
- v. To replace any of the Fan(s) (unit may remain powered):
 - 1. Remove the screws securing the fan shroud.
 - 2. Disconnect the electrical connectors to the fan(s) to be replaced.
 - 3. Remove the screws securing the fan(s) to be replaced.
 - 4. Remove and replace the fan(s) with the appropriate part(s).
 - 5. Reverse steps 1-3 to reassemble.

6. Optical Issues

- a. Input Power LED in major/minor alarm.
 - i. Ensure input ~ 1550nm signal power and wavelength are with the specifications provided for the unit.
 - ii. Use **RI P** command to verify if monitored input power of the unit agrees with power measured by external optical power meter.
 - 1. If there is a power reading difference then ensure the optical fiber end-faces of the supply fiber and internal input connector of the unit are clean and correctly mated.
 - 2. Check for fiber and connector damage.
- b. Video Service Quality issues.
 - i. Measure the optical output power of the optical output port(s) with issues. Check that they are at correct operating level for the installation.
 - ii. Use **ROP** command to verify if monitored output power of the unit agrees with output power measured by external optical power meter.
 - iii. Ensure that low power mode has not been selected. Use Low power button on front panel to toggle low power/normal operation (hold for approx. 3 seconds to change state, allow 10 seconds for state change to occur after button release).

- iv. Use local Video diagnostic equipment to confirm quality of input video overlay optical signal.
 - v. Use local Video diagnostic equipment to confirm quality of amplified video overlay optical signal using the monitor port of the unit.
 - vi. **Increase** optical output power of the unit (affects all ports) to boost signal to overcome loss.
 - vii. **Decrease** the optical output power of the unit (affects all ports) to reduce the detrimental effects of SBS. (Quality of SBS suppression is determined by the optical CATV video transmitter that is input to the EDFA unit)
 - viii. If Input optical power and wavelength in specification and optical output is enabled and the unit is not in low power mode yet there is an output power minor or major alarm or pump diode minor or major alarm it may indicate internal failure of the unit.
- c. 1310/1490nm Voice/Data Service issues (**CWDM units only**)
- i. If there are issues with 1310nm/1490nm Voice/Data CWDM ports then check the loss of the OSC-OS port routings with the EDFA disabled. If the loss is

LED Status Indication

1. LED Status Table

LED	Color	Alarm	Other Indication	Condition
All LED's	Green	None	Data or Voice failure but Video OK	Some Blue ports have weak or no signal output and no EDFA alarm-Video not affected
All LED's	Green	None	Weak or no video signal to entire neighborhood fed off that port	Some Green Ports have weak or no output - no EDFA Alarm but Data/voice affected on same ports
48V Sup	Red	Major	no other LED's affected	Blown Fuse
48V Sup	Amber	Minor	no other LED's affected	48V Power Supply Feed Missing
48V Sup	Green	None	-	-
Equip	Red	Major	no other front panel LED's affected, Power Supply LED not on	Power Supply unit has failed or is unplugged
Equip	Amber	minor	no other LED's affected	Temp alarm active
Mode	Amber	Major	Equip-Red	Interlock Connection open
Mode	Amber	Minor	no other LED's affected	Key-switch is off
Pwr In	Red	Major	Mode-Red, Equip-Red	Optical Input Failure
Pwr In	Amber	Minor	Equip-Amber	Optical Input below or above threshold
Pwr In	Green	None	-	-
Pwr Out	Amber	Minor	Equip-Amber	Output optical Power is below or above preset threshold alarm
Pwr Out	Red	Major	Equip-Red, Mode-Amber	Optical Output has fallen below critical levels and has been shut off
Fan	Red	Major	Red Fan LED Lit and Red Equipment LED	Fan or Airflow failure
Pump	Red	Minor	No other LED indications	Pump Current below or above thresholds

2. Minor Alarms

When present the laser emission remains ON. An alarm message is displayed on the front panel, and the Minor Alarm indicator is illuminated. Minor Alarm conditions will reset automatically when operating conditions are within the design threshold.

3. Major Alarms

When present the laser emission is turned OFF. An alarm message is displayed on the front panel, the Major Alarm indicator is lit steady and the Alarm relay contacts on the rear panel are deactivated. In normal operation the relay is energized.

Major Alarms will reset and emission will resume if the alarm condition is corrected. The exception is the "Output Power Off" Major alarm which requires the emission key to be cycled to regain amplifier operation.

RS-232 Interface Commands

RS-232 Command	Code	Units	Notes
Read Model #	RMDL	-	Returns the Model Number
Read Serial #	RSN	-	Returns the Serial Number
Read date of manufacture	RDATE	-	Returns the date of manufacture
Read Firmware Revision	RREV		Returns the revision level of the firmware.
Set the IP address	SIP		
Set the gateway address	SGATE		
Set the network mask	SNET		
Get the IP address	GIP		Type a space after the opcode & before hitting the Return or Enter key
Get the gateway address	GGATE		Type a space after the opcode & before hitting the Return or Enter key
Get the network mask	GNET		Type a space after the opcode & before hitting the Return or Enter key
Read control mode type	RCM	-	Returns either "POWER", "CURRENT" or "GAIN" for the control mode type
Read Measured Gain value	RMG	dB	Returns "Gain = xx.x"
Read Gain setpoint value	RGS	dB	Returns "Gset = xx.x"
Read Minimum Gain Setpoint	RMINGAIN	db	Return the minimum gain that can be set in AGC mode "Gmin = xx.x"
Read Maximum Gain Setpoint	RMAXGAIN	db	Returns the maximum gain that can be set in AGC mode, in the format "Gmax = xx.x"
Read Total optical Output power	ROP	dBm	Returns "Pout = xx.x"
Read Constant Output Power value	RPS	dBm	Returns "Pset = xx.x"
Read Maximum Power Setpoint	RMP	dBm	Returns "Pmax = xx.x"
Read Current Setpoint value	RCS	Amps	Returns "Iset = x.xxx"
Read Maximum Current Setpoint	RMC	Amps	Returns "Imax = x.xxx"
Read pump laser current	RLC	Amps	Returns "lmeas = x.xxx"
Read Ambient Temperature	RAT	Deg. C	Returns "Amp. = XX deg C"
Read Total optical Input power	RIP	dBm	Returns "Pin = x.xx" NOTE: this value could be negative and/or have 2 digits containing 1 decimal point; i.e. -12, -2.2, 0.0, 3.5
Read Temperature Alarm Threshold	RTEMPHRESH	Deg. C	Returns "AMP. minor alarm = XX deg C" Which = the current minor alarm value. major alarm temp > minor alarm temp
Read "Input Power Low" Alarm Level	RPINLOW	dBm	Returns: "Pin Low Alarm Level = xx.x" NOTE: this value could be negative and/or have 2 digits containing 1 decimal point; i.e. -12, -2.2, 0.0, 3.5
Read "Input Power Off" Alarm Level	RPINOFF	dBm	Returns: "Pin Off Alarm Level = xx.x" NOTE: this value could be negative and/or have 2 digits containing 1 decimal point; i.e. -12, -2.2, 0.0, 3.5
Read "Input Power High" Alarm Level	RPINHIGH	dBm	Returns: "Pin High Alarm Level = xx.x" NOTE: this value could be negative and/or have 2 digits containing 1 decimal point; i.e. -12, -2.2, 0.0, 3.5
Read "Input Power Too High" Alarm Level	RPINTOOHIGH	dBm	Returns: "Pin Too High Alarm Level = xx.x" NOTE: this value could be negative and/or have 2 digits containing 1 decimal point; i.e. -12, -2.2, 0.0, 3.5
Read "Output Power Low" Alarm Level	RPOUTLOW	dBm	Returns the threshold level for the "Output Power Low" alarm, in the format "Pout Low Alarm Level = xx.x"
Read "Output Power Off" Alarm level.	RPOUTOFF	dBm	Returns the "Output Power Off" Alarm threshold, in the format "Pout Off Alarm Level = xx.x"
Read the Autorestore Input Power Threshold	RAUTOTHRESH	dBm	Returns the threshold for the automatic restoration of emission, in the format "Autorestore Level = xx.x"
Enable Access to the provisioning commands.	LOGIN	-	This command must be followed by the 6 digit passcode to enable access to the provisioning commands. Default Value is 999999
Read Status Value	STA	-	Returns the status of the unit encoded as a 32 bit integer. Bit 0 - Temperature Alarm Bit 1 - Fan Alarm Bit 2 - Output Too High Alarm Bit 3 - Output High Alarm Bit 4 - Output Low Alarm Bit 5 - Input Too High Alarm Bit 6 - Input High Alarm Bit 7 - Input Low Alarm Bit 8 - Output Off Alarm

RS-232 Command	Code	Units	Notes
			Bit 9 - Input Off Alarm Bit 10 - Interlock Bit 11 - Power Supply 1 Failed Alarm Bit 12 - Power Supply 2 Failed Alarm Bit 13 - Reserved Bit 14 - Emission On Bits 15 - 31 are reserved.
Read Relay Alarm Status	RRAS	-	Returns the alarms that are assigned to trip the alarm relay.
Read Relay Status	RRS	-	Returns the state of the relay "Normal" or "Tripped"
Read Alarm Status	RAL	-	Returns the individual alarm conditions within the Laser.
Read "Output Power High" Alarm Level	RPOUTHIGH	dBm	Returns: "Pout High Alarm Level = xx.x" NOTE: this value could be negative and/or have 2 digits containing 1 decimal point; i.e. -12, -2.2, 0.0, 3.5
Read "Output Power Too High" Alarm Level	RPOUTTOOHIGH	dBm	Returns: "Pout Too High Alarm Level = xx.x" NOTE: this value could be negative and/or have 2 digits containing 1 decimal point; i.e. -12, -2.2, 0.0, 3.5
Read Minimum Current Adjust when in ACC Mode	RACCNUDGEMIN	Amps	*Returns "ACCNudgeMin = x.xxx"
Read Maximum Current Adjust when in ACC Mode	RACCNUDGE MAX	Amps	*Returns "ACCNudgeMax = x.xxx"
Read Current Adjust Step Size when in ACC Mode	RACCNUDGESTEP	Amps	*Returns "ACCNudgeStep = x.xxx"
Read Minimum Power Adjust when in APC Mode	RAPCNUDGEMIN	dBm	*Returns "APCNudgeMin = xx.x dBm"
Read Maximum Power Adjust when in APC Mode	RAPCNUDGE MAX	dBm	*Returns "APCNudgeMax = xx.x dBm"
Read Power Adjust Step Size when in APC Mode	RAPCNUDGESTEP	dB	Returns "APCNudgeStep = xx.x dBm"
Read Minimum Gain Adjust when in AGC Mode	RAGCNUDGEMIN	dB	Returns "AGCNudgeMin = xx.x"
Read Maximum Gain Adjust when in AGC Mode	RAGCNUDGE MAX	dB	Returns "AGCNudgeMax = xx.x"
Read Gain Adjust Step Size when in AGC Mode	RAGCNUDGESTEP	dB	Returns "AGCNudgeStep = xx.x"
Read Default Minimum Current Adjust when in ACC Mode	RFDACCNUDGEMIN	Amps	Returns "FD ACCNudgeMin = x.xxx"
Read Default Maximum Current Adjust when in ACC Mode	RFDACCNUDGE MAX	Amps	*Returns "FD ACCNudgeMax = x.xxx"
Read Default Minimum Power Adjust when in APC Mode	RFDAPCNUDGEMIN	dBm	*Returns "FD APCNudgeMin = xx.x dBm"
Read Default Maximum Power Adjust when in APC Mode	RFDAPCNUDGE MAX	dBm	*Returns "FD APCNudgeMax = xx.x dBm"
Read Default Minimum Gain Adjust when in AGC Mode	RFDAGCNUDGEMIN	dB	*Returns "FD AGCNudgeMin = xx.x"
Read Default Maximum Gain Adjust when in AGC Mode	RFDAGCNUDGE MAX	dB	*Returns "FD AGCNudgeMax = xx.x"

*= Applies to models with front panel LCD Only

RS-232 Provisioner Commands

RS-232 Command	Code	Units	Notes
Set Control Mode to APC	SMPC	-	Sets the control mode of the unit to Power Control.
Set Control Mode to AGC	SMGC	-	Sets the control mode of the unit to Gain Control.
Set Control mode to ACC	SMCC	-	Sets the control mode of the unit Current Control.
Set Output Power Setpoint	SOP	dBm	Sets the APC mode setpoint.
Set Gain Control Setpoint	SGS	dB	Sets the AGC mode setpoint.
Set Current Control Setpoint	SLC	Amps	Sets the ACC mode setpoint.
Set "Input Power Low" alarm level	SPINLOW	dBm	Sets the threshold level for the "Input power Low" alarm. Overrides the factory default setting.
Read Factory Default "Input Power Low" Alarm Level.	RFPINLOW	dBm	Reads the factory default setting for the "Input Power Low" alarm level.
Restore access level to user mode.	LOGOUT	-	Disables access to the provisioning commands.
Change the access pass code for the provisioning commands.	PASSCODE	-	Sets the new passcode. The passcode must be a 6 digit number. Default Value is 999999
Restore all parameters to their factory defaults.	RESTORE	-	
Set Relay "Input Power Low" Alarm Status.	SRAPINLOW	See Note	Enables or disables activation of the relay for the alarm 0 Disables the alarm, 1 Enables the alarm.
Set Relay "Input Power High" Alarm Status.	SRAPINHIGH	See Note	Enables or disables activation of the relay for the alarm 0 Disables the alarm, 1 Enables the alarm.
Set Relay "Input Power Too High" Alarm Status.	SRAPINTOOHIGH	See Note	Enables or disables activation of the relay for the alarm 0 Disables the alarm, 1 Enables the alarm.
Set Relay "Output Power Low" Alarm Status.	SRAPOUTLOW	See Note	Enables or disables activation of the relay for the alarm 0 Disables the alarm, 1 Enables the alarm.
Set Relay "Output Power High" Alarm Status.	SRAPOUTHIGH	See Note	Enables or disables activation of the relay for the alarm 0 Disables the alarm, 1 Enables the alarm.
Set Relay "Output Power Too High" Alarm Status.	SRAPOUTTOOHIGH	See Note	Enables or disables activation of the relay for the alarm 0 Disables the alarm, 1 Enables the alarm.
Set Relay "Fan Failure: Alarm Status	SRAFAN	See Note	Enables or disables activation of the relay for the alarm 0 Disables the alarm, 1 Enables the alarm.
Set Laser "Ambient Temperature High" Alarm Status.	SRATEMP	See Note	Enables or disables activation of the relay for the alarm 0 Disables the alarm, 1 Enables the alarm.
Set Minimum Current Adjust when in ACC Mode	SACCNUDGEIN	Amps	Sets the minimum current that can be adjusted from the front panel interface using the minor adjust feature when the unit is in ACC mode. Overrides the factory setting.
Set Maximum Current Adjust when in ACC Mode	SACCNUDGEIN	Amps	Sets the maximum current that can be adjusted from the front panel interface using the minor adjust feature when the unit is in ACC mode. Overrides the factory setting.
Set Minimum Power Adjust when in APC Mode	SAPCNUDGEIN	dBm	Sets the minimum output power that can be adjusted from the front panel interface using the minor adjust feature when the unit is in APC mode. Overrides the factory setting.
Set Maximum Power Adjust when in APC Mode	SAPCNUDGEIN	dBm	Sets the maximum output power that can be adjusted from the front panel interface using the minor adjust feature when the unit is in APC mode. Overrides the factory setting.
Set Minimum Gain Adjust when in AGC Mode	SAGCNUDGEIN	dB	Sets the minimum gain that can be adjusted from the front panel interface using the minor adjust feature when the unit is in AGC mode. Overrides the factory setting.
Set Maximum Gain Adjust when in AGC Mode	SAGCNUDGEIN	dB	Sets the maximum gain that can be adjusted from the front panel interface using the minor adjust feature when the unit is in AGC mode. Overrides the factory setting.



All products, manuals and data sheets are subject to change without notice.