

T2 2-Piece Series Trunk & Distribution Connectors

Introducing the new Toner Cable line of T2 Series 2-Piece Coaxial Hardline Connectors. These aluminum connectors meet industry standards at an affordable price for 75 Ω coaxial CATV distribution cable. These connectors are for both Times Fiber T10 series .500 cable and CommScope P3 series .500 cable, as well as many other that meet the same specifications.

Common Specifications

Bandwidth: 5 MHz to 1250 MHz
Impedance: 75 Ω
Return Loss: 30 dB
Shielding: 120 dB
Insertion Loss: < 0.2 dB
Thread: 5/8 -24 UNEF
Aluminum: 6061
Finish: Chromatic Acid Anodizing
Pin Length: 2.25"
O Ring: Silicone Rubber
Cable Retentions: 55 lbs (25 kg)
Temperature Range: -40 to 115°F (-40 to 45°C)

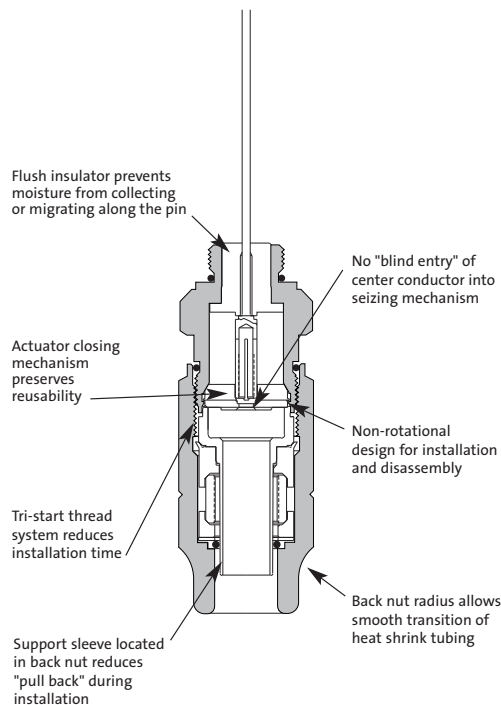

T2-500-CH-P3

Pin Type Connector for .500 Coax Cables



T2-F-625-CH-T

Male Pin Type to F-Female Adapter



T2-CH-BAFF

Pin Type to F-Female Adapter



T2-500-SP-P3

Splice Type Connector for .500 Coax Cables



T2-CH-KS-KS-M

CH Port Housing to Housing Adapter



T2-CH-TRM

CH Port Terminator

