

TDA31-34/1200 CATV Distribution Amplifier

Model	Bandwidth
TDA31-34/1200	5-85 MHz / 105-1200 MHz



The Toner two way apartment house type amplifiers with active return are broadband indoor GaAs E-pHEMT Push Pull distribution amplifiers designed for 1.2 GHz DOCSIS 3.1 supported RF distribution systems such as those in Cable Television Apartments, Hotels, Hospitals and other applications where a high quality low noise figure amplifier is necessary to amplify the signals in both the forward and return paths.

Designed for flat operational gain of 35 dB in the forward path and 18 dB in the reverse path. They have an input equalizer and interstage equalization feature in the forward bandwidth for balancing, a forward input gain control, input and output reverse gain controls.

Universal JXP style pads applicable for both attenuator and equalizer functions.

The amplifiers are powered by a plug in wall type 12VDC power transformer that is available in either 117 or 230 volts.

FEATURES

- 1.2 GHz forward bandwidth (DOCSIS 3.1 supported),
- GaAs E-pHEMT Push-Pull design for high output levels with low distortions and very high efficiency,
 - Input gain and equalization controls,
 - Mid-stage equalizer,
- All gain and equalizer controls by plug-in JXP style components,
 - Die cast aluminum housing for heat dissipation,
 - Maximum RFI Shielding,
 - SCTE compliant F type connectors,
- External input and output bi-directional test points,
 - External powering (10-36VDC).

SPECIFICATIONS (Typical)

Typical, for T = 20degC, Z_{in} = Z_{out} = 75 ohms

Parameter	Notes	Forward	Reverse	Units
Bandwidth		105-1200	5-85	MHz
Technology		GaAs E-pHEMT	Si-Bipolar	
Average Full Gain		35	18	dB
Flatness		+/-1	+/-1	"
Return Loss, IN/OUT		-14	-16	"
Test Points, IN/OUT		In & Out : -20dB	In & Out : -20dB	"
Gain Control	0.45" JXP Plug-in	In:	In&Out:	
Slope Control	0.45" JXP Plug-in	In&Mid	-	
Forward Distortions:	42dBmV (105-1000 MHz) flat output level, 79 NTSC channels, digital at -6dB after 600MHz			
CTB		-59		dBc
CSO		-64		"
Xmod		-60		"
Forward Distortions:	34/46dBmV (105-1000 MHz) output level, 79 NTSC channels, digital at -6dB after 600MHz			
CTB		-63		dBc
CSO		-66		"
Xmod		-63		"
Reverse Distortions:	48dBmV flat output on each of CH T8 and T9 according to ANSI/SCTE115 2011			
DTO	(on 7 & 25MHz)		-75	"
DSO	(on 6 & 32MHz)		-60	"
Xmod	(on T8,9)		-75	"
Noise Power Ratio (NPR or CINR)	dB, max		64 @ 24dBmV input power	
Input Dynamic Range @ NPR=41dB			46dB (-3.....43dBmV)	
Noise Figure	with 0dB jumpers	<6	<6	dB
Hum Modulation			<-80	dBc
RFI Isolation			-90	"
Surge Withstand	IN/ OUT	IEEEC62.41 Cat.A3(6kV,200A)		
Powering		10 - 36 VDC external via F-Type Connector		VDC
Power Consumption		4		Watts
Temperature		-30 to +55		degC
Enclosure		IP54 Category, Diecast Aluminium		
Dimensions		105 * 125 * 50 (4,15" * 4,92" * 1,97")		mm (in)
Weight		0.7 (1.6)		kg (lb)

Block Diagram

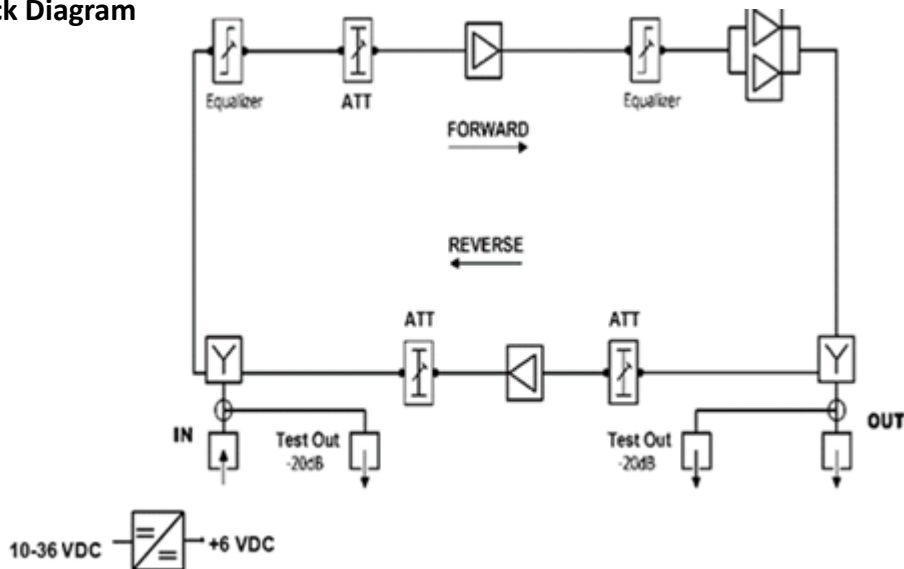

The Lightning flash with arrowhead symbol within an equilateral triangle is intended to alert you to the presence of uninsulated "dangerous voltage" within the products supplementary external power supply enclosure that may be of sufficient magnitude to constitute a risk of electrical shock to persons.

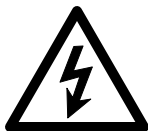

CAUTION

**Risk of Electric Shock
Do not Open**



The exclamation point within an equilateral triangle is intended to alert you to the presence of important operating and maintenance (servicing) instructions in the literature accompanying the product.

**REMEMBER TO REPLACE COVER AFTER ADJUSTING.
COVER MUST BE IN PLACE FOR CE, SAFETY AND PROTECTION.**

NO SERVICEABLE PARTS INSIDE. REFER SERVICING TO QUALIFIED SERVICE PERSONNEL.

WARNING: TO PREVENT SHOCK HAZARD, DO NOT EXPOSE THIS UNIT TO RAIN OR MOISTURE. THIS APPARATUS SHALL NOT BE EXPOSED TO DRIPPING OR SPLASHING WATER AND NO OBJECTS FILLED WITH LIQUIDS, SUCH AS VASES, SHALL BE PLACED ON THE APPARATUS.
WARNING: THIS PRODUCT IS A CLASS-I CONSTRUCTION. PLEASE ENSURE A CONNECTION TO MAINS SOCKET WITH A PROTECTIVE EARTHING CONNECTION.

NOTE TO CATV SYSTEM INSTALLER

This reminder is provided to call the CATV System Installer's attention to Article 820-40 of the NEC that provides guidelines for proper grounding and, in particular, specifies that the cable ground shall be connected to the grounding system of the building, as close to the point of cable entry as practical.

INSTALLATION GUIDELINES

1. Plug in Gain & Cable Slope Controls are reachable under the Cover. Refer to layout scheme above the RF circuit for adjustable controls.
2. This product is shipped with default 0 dB pads for plug in gain control and equalization.
3. Connect only to power adapter supplied with the amplifier.

FORWARD OUTPUT LEVEL SETUP PROCEDURE for TDA31-34/1200 :

1. Before applying power to the amplifier, make sure that the input level to the amplifier is not too high otherwise a damage to the amplifier might occur. To be on the safe side, you should set the input gain control adjustment to minimum gain (insert highest pad on input ATT socket) before powering the TDA.
2. Set the input and interstage equalizer controls for minimum slope, install a 0 dB JXP pads at the input and interstage plug in equalizer sockets (factory installed).
3. Now apply power to the amplifier and measure the amplifier output level at the - 20 dB output test point. If it is low, then place appropriate pad into the input ATT socket to increase the gain the desired output level at the highest operating frequency. Remember that the level measured at the test point is 20 dB lower than the real signal level.
4. Place an appropriate plug-in JXP Pad module into the input equalizer socket to ensure flat signal level across the full bandwidth. The input signal level will now be flat too. Under this condition there will be best CNR across the full bandwidth.
5. Now install a plug-in JXP Pad module into the midstage equalizer socket to get as close as possible to the desired output signal slope. The desired output slope is determined by your system design. Consult your system planner or your system maps for this information. JXP style attenuators are available in 2 dB steps from 0 to 18 dB.
6. Make a final adjustment of the output level with the input gain control. Always adjust the gain control, then the slope control in that order.
7. Remember to replace the cover after adjusting.

MECHANICAL DIMENSIONS for 0.45" JXP STYLE PADS

(applicable for both attenuator and equalizer functions)

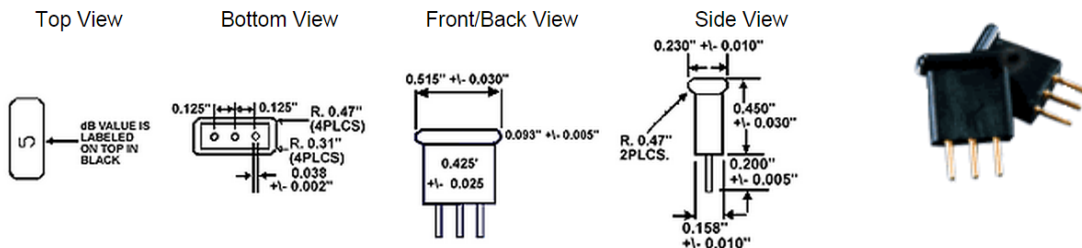

INSTALLATION PRECAUTIONS TABLE

PRECAUTIONS	REQUIREMENT
Facilitate service and maintenance	Allow a minimum of 35 in.(90 cm) clearance in front of the equipment rack(s)
Avoid direct heating or air conditioning	If unavoidable, use deflector plates
AC Power source outlets	Locate equipment near sufficient outlets to provide power for test equipment and power tools.
Rack support	Make certain rack supports are sufficiently rigid to support rack(s)
Building leakage	Beware of dripping water onto equipment from leaky roofs, waveguide roof entries, and cold water pipe condensations.