

Product Manual

ICC1-232

RS-232 Display Controller, 1-way Control

Ver. 5 June 30, 2016

Table of Contents

Overview	3
Specifications	4
Physical	4
Rear Panel	4
iCC-Net	4
Includes	4
Options	4
Installation	5
AC Power Test	5
RS-232 Control Wiring	5
RF Coax and iCC-Net Operation	5
RS-232 Control Codes	5
Setting Device Number and Parameters	6
Installation Process and Documentation	6
Power-Up and Lock Logic	7
Input Selects	7
TV Information	7
RS-232 Control Protocol	8
Overview	8
Command String Structure	8
Writing Your Own Control Code	9
RS-232 Commands	10
Safety Instructions	12
Limited Warranty and Disclaimer	12

Overview



The ICC1-232 RS-232 Display Controller delivers economical 1-way control for power, volume, channels, and available control lockout commands, receiving iCC-Net network commands over the same broadband coax that carries the CATV channels. Compact in size and price, the ICC1-232 features discrete power control and intelligent tuning from a channel list stored in onboard non-volatile memory. Tuning options include analog- and HDTV-format channels.

High-speed 1-way control is possible through the same RF cable that carries the TV channels, creating networked operation of distributed media systems without adding control wiring. Compatible with the Contemporary Research Display Express software, the ICC1-232 can be networked with up to 4000 display controllers. For custom systems applications, the ICC1-232 and other CR display controllers can be accessed from a single RS-232 or Telnet port on an ICE-HE Ethernet Head End.

Applications include signage and video distribution for retail stores, theme parks, museums, government facilities, sports venues, worship spaces, convention centers, airports and corporate video networks..

- Controls most brands of RS-232-controlled displays
 - Delivers absolute power control with discrete RS-232 commands
 - Tunes analog or HDTV format channels
 - Intelligent volume level and mute operation
 - Enables available control lockout commands
- Networks with up to 4,000 TVs through the ICE-HE Ethernet Head End
- Receives 1-way individual and zone commands from a single RS-232/Telnet port on the ICE-HE Head End
- Provides LED feedback for network and RS-232 control
- Restores all power and channel status after loss of power from data stored in non-volatile memory
- Mounts on the back of display for simplified control and RF installation
- Operates with Display Express software, as well as custom control systems
- Includes RF loop cable, mounting Velcro, and 12VDC power supply
- Optional CC-COM RS-232 control cable or custom CC-232 cable (specify make, model, and cable length)

Specifications

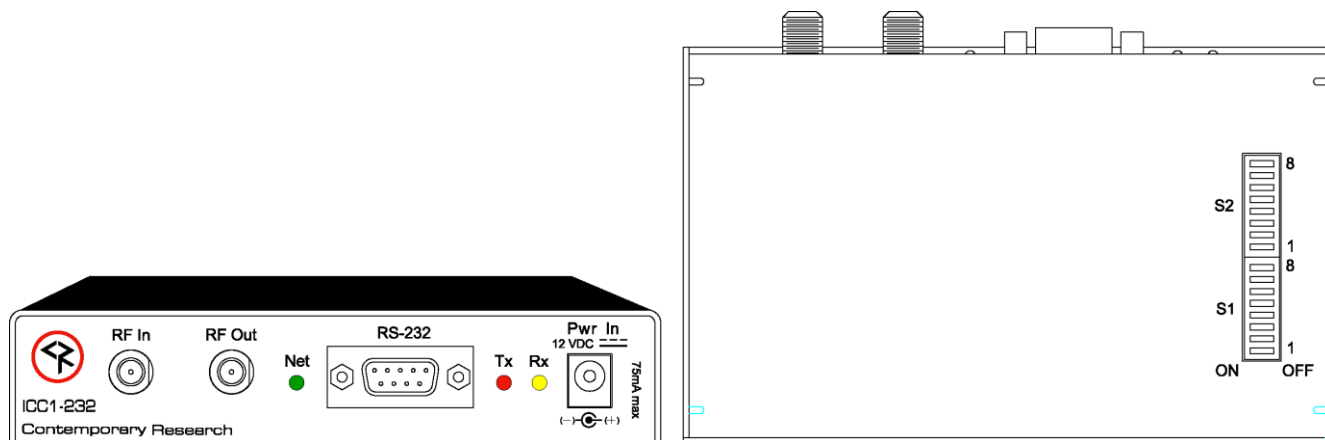

Physical

Size:	5.5" [140mm] wide x 1.1" [28mm] height x 3.4" [86mm] deep
Weight:	8 oz [226g]
Enclosure:	All aluminum with durable black powder coat paint
Mounting:	Mounts rear of TV

Rear Panel

RF In	'F', female, 75 ohm impedance, RF from CATV system, iCC-Net control
RF Out:	'F', female, 75 ohm impedance, RF to TV, less than -1.5 dbmV loss
Net LED:	Green LED for iC-Net bus and DC power, flashes once per second if active
RS-232:	DB-9 male connector, baud rates from 1200 to 115K baud Optional CC-232 RS-232 available to match specific makes and models
Tx LED:	Red LED lights when RS-232 information is sent
Rx LED:	Yellow LED lights when RS-232 information is received
Power In:	2.1mm coaxial jack (inside center conductor positive), 75 mA maximum 11.5 to 16.5 VDC, 12 VDC typical (may be unregulated)
DIP Switches:	Located on bottom of unit, sets RS-232 code operation and device number

iCC-Net

Operation:	1-way control, carried over the same RF coax connection as TV channels
Data Receive:	Mid-band VHF, 74.7 MHz, sent from ICC-HE -25 to +35 dBmV signal level

Includes

- RF Loop cable, 18"
- 12 VDC power supply, 500 mA, (domestic US shipments only)
- Mounting Velcro

Options

- CC-COM Null Modem cable, 6'
- CC-232 RS-232 Control Cable (specify make, model, and length)
- 12 VDC power supply, 100 mA, (domestic US shipments only)

Installation

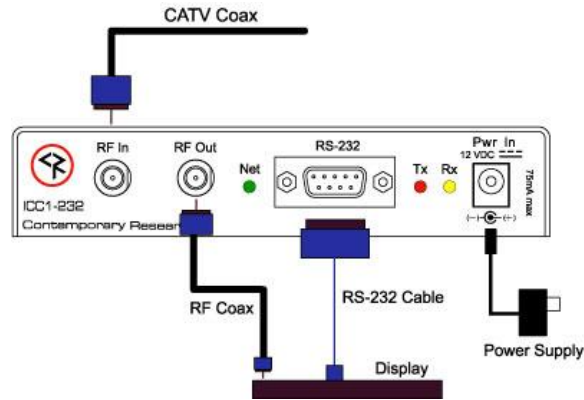

AC Power Test

1. Insert DC power supply plug into 12 VDC jack.
2. Plug power adaptor into AC wall outlet.
3. The Net LED should turn on and stay lit.
4. When an RF feed is connected to RF with an installed ICE-HE, LED will blink once a second

RS-232 Control Wiring

1. Attach the CC-RS-232 or custom RS-232 cable to the ICC1-232 control port.
2. Connect the cable to the display's RS-232 control input.

RF Coax and iCC-Net Operation

1. Connect the TV to CATV and observe quality of RF broadcasting. A low-quality CATV system can also affect performance of the iCC-Net commands. If needed, fix CATV problems before installing the system.
2. Connect the CATV RF Coax cable into the RF In input on the ICC1-232.
3. If the iCC-Net signal is operating, the Net LED will blink once per second.
4. Connect the RF loop cable from the RF Out jack to the TV's RF connector (remember, you lose less than 1.5 dbmV by going through the ICC1-232'S internal RF tap).

RS-232 Control Codes

Presently, one control type is installed at the factory, updateable to other types through the RF or via RS-232. The list below includes current makes and models of RS-232 controllable TVs, there are more codesets available for legacy TVs.

Make	Type	Notes
Contemporary TVs		
LG 2	LCD	Includes input selects for current models
NEC	LCD	Older M-series with AVT tuner
NEC	LCD	New M,P,S,V,X-AVT and E-series TVs
NEC	LCD	E-series
Panasonic	LCD	LRU and LRG series
Samsung	LCD	DM,MD, ME, HD series commercial TVs
Sharp	LCD	Codes for existing TVs made by Sharp
Sunbrite	LCD	
Viewsonic	LCD	Commercial TVs

RS-232 Pinouts

- Pin 5 = Ground (GND)
- Pin 2 = Receive (RX)
- Pin 3 = Transmit (TX)

Setting Device Number and Parameters



In the next step, you'll need to set up the device number and operation parameters for the ICC1-232. Turn the enclosure so that the DIP switches are on the bottom as shown.

1. Make sure **S2** Switch 6 is OFF (unit in Device mode).
2. Set the **Device number** by turning on the switches that add up to the desired device number. For example, for Device #259, turn on S1 switches 1 and 2 (3), S2 switch 1 (256)

Zone Switch Settings

To define the controller's Zone #, use the following pattern of switches ON for the S2 DIP.

Zone	Value	1	2	3	4
		256	512	1024	2048
1	256	X			
2	512		X		
3	768	X	X		
4	1024			X	
5	1280	X		X	
6	1536		X	X	
7	1792	X	X	X	
8	2048				X
9	2304	X			X
10	2560		X		X
11	2816	X	X		X
12	3072			X	X
13	3328	X		X	X
14	3584		X	X	X
15	3840	X	X	X	X

Installation Process and Documentation

Most dealers will pre-configure the controller's address before hanging displays. After setting the address, use a label that states the unit's address and location. Some use this method:

Room 305 - 515 - 12/2

The first identifies the location/name of the display. The second shows the specific address. The last set shows the switches in S1/S2 that are set to ON.

It's a good idea to define this first in a spreadsheet, with the columns defining the name, address, S1 and S2 ON settings. Then, one person can set up all the controllers and label them.

Once the controller is configured and labeled, it's easier for less-trained installers to Velcro the controller on the back of the display, provide power, and hang the displays. It's much easier to pre-configure ahead of time than perform the task once the displays are installed.

Power-Up and Lock Logic

The ICC1-232 remembers the current power and Lock state of the connected TV so that the controller can restore power and operation lock to the TV when AC power is restored. Some TVs, such as LG, will lose the locked state (no local button or IR control) when the set loses AC power. Other sets may not automatically power back on when AC power is restored.

To deal with this issue, after every power-up or reset, the ICC1-232 will transmit its current (last commanded) power control string (Power On or Power Off) to the TV, as well as work to restore the Lock state.

If the TV was On and Locked when power was lost, the controller will send a Power On command when power is restored, then sends a Lock command after a time delay. This assures that the TV stays locked when it is automatically powered up after a reset.

If the TV was Locked and Off when power was lost, the controller will send a Power Off command every 16 seconds when power is restored. When a command is sent to turn the TV on, the controller will also send a Lock command after a time delay.

Input Selects

The code sets listed a Contemporary TVs in the list on Page 5 have the ability to select inputs from a special channel command, 0-NNN. For example, a 0-211 command would send the TV to the HDMI 1 input. For some makes, such as LG, you need to send a TV/Tuner command (0-200) to restore the TV to the current channel. For other sets, sending a channel command automatically selects the tuner if it's at a different input. The command list covers all the possibilities, not all sets have every option.

115=Captions	206=Component1	211=HDMI1
200=TV/Tuner	207=Component2	212=HDMI2
201=Video1	208=RGB1	213=HDMI3
202=Video2	209=RGB2	214=HDMI4
203=Video3	210=RGB3	215=HDMI5
204=S-Video1		
205=S-Video2		

TV Information

Go to our Support Blog ["Display Express TV Guide"](#) for up-to-date information on makes and models.

LG	Codes have stayed consistent in general. Newer models use different codes for inputs than previous models. A codeset is available for older models as well.
NEC	There are three current codesets: <ul style="list-style-type: none">• M/P/S/V with AVT Tuners• E-series TVs with integrated tuner• E-Series TVs with AVT tuner
Panasonic	LRU and LRG series are supported
Sharp	The current codeset is for previous prosumer Sharp TVs that supported RS-232 control. <ul style="list-style-type: none">• Send an H9.1 command via DX or control system for sets that can tune XX.1 channels• Send an Off command to all TVs, manually turn on TVs, then send an OFF command – this turns off the Energy Star feature that turns off RS-232 when the TV is off.
Samsung	<ul style="list-style-type: none">• All commercial models are supported.• Samsung TVs that support X-Link control, the commands are different than commercial TVs and can only access Major and Minor channels up to 63.
Viewsonic	The commercial line is very new – a codeset is available

RS-232 Control Protocol

Overview

RS-232 control for up to 4000 TV Controllers is provided through an iC-series Head-End Network Controller. The ICE-HE Ethernet Head End manages iC-Net communication over RF Coax to ICC1 (1-way) and ICC2 (2-Way) TV Controllers.

Each TV Controller is assigned a unique device number from 1 to 4000 to which control commands are addressed. The devices are organized into 16 zones of 255 devices. All the devices in each zone will respond to a single “virtual device number” — one device number that represents all devices in each zone. There is also a global device number, 4095, that will command all devices in the system. This feature dramatically speeds up system operation and programming, because one command can affect an entire group of devices—or all. To take advantages of this feature, review the section **iC-Net SmartZones** in this manual.

In ABC-Net, we reserve the first group of devices, 1-255, for components operating on a connected control system. Zones 1-16 are used for CR TV Controllers, Video Display Controllers and Tuners. As it’s unlikely any system will use all 4000 devices, this may be a good device standard for your system as well.

The Remote RS-232 port on the Head-End Network Controller can communicate from 1200 to 38.4K baud. The factory default setting is 19.2K baud, 8 data bits, No parity, and 1 stop bit.

Command String Structure

Characters in command strings are expressed in a combination of hex and ASCII characters. For clarity, the following protocol examples use the following conventions:

- Single-byte hex numbers are preceded by the ‘\$’ symbol
- ASCII characters or strings are enclosed in single quotes
- Numbers not marked as hex or ASCII are a single decimal byte
- Parameters shown in < > brackets are single byte
- A series of multiple commands or parameters are set apart by [] brackets
- Commas separate the bytes, but are not part of the protocol
- Double quotes enclose the command string, but are not part of the protocol

Command format:

“\$A5,<dh>,<dl>,<ncb>,<cmd1>,<parameter> [<cmdN>]”

\$A5	Starts the command
<dh>	The zone or high order byte of the device*
<dl>	The unit or low order byte of the device (0 for global zone)
<ncb>	The number of command bytes to follow
<cmd1>	The first command byte
<parameter>	Command parameters (not used by all commands)
[<cmdN>]	Multiple commands can be concatenated, with byte count added to <ncb>

Writing Your Own Control Code

While most IC systems use our Display Express software to control displays, a growing number of integrators are writing their own control applications, using AMX, Crestron, RTI, or other platforms. We encourage creative solutions, and are happy to support those who take advantage of our protocol.

From our history of support activity, we are providing a few tips to help you on your way.

Device Numbers

iC-Net devices are arranged with a zone structure, arranged in 15 groups of 256 devices. The first address in the group represents the entire zone. For example, Zone 2's group address is 512 (2*256). When a command is sent to 256, all controllers in that group will respond as one.

The Device values reflect that structure. The first number <dh> is the zone, from 1-15. The second defines the unique address of the device, 1-255). For example, a command sent to Device 256, which triggers all the units in Zone 1, would be expressed as \$A5, 1, 0 (first zone, device zero). A command sent to 257 would be \$A5, 1, 1 (first zone, device 1 in the zone). See iC-Net Zones toward the end of this manual.

String Format

Every software application has a different denotation for handling hex, ASCII, and decimal formats. The examples in this manual are in AMX format, which is understood by many in the control industry:

- Hex values begin with a dollar (\$) symbol
- ASCII values are enclosed in single quotes
- Decimal values are shown as normal

If you plan on using a mixed-format structure for commands, convert the symbols to the types required by your software application. For example, a **Tune Channel 2-3** command to device 260 could be shown several ways:

- AMX Mixed Format = "\$A5,1,4,5,'TH',2,2,3"
- AMX Hex Format "\$A5 \$01 \$04 \$05 \$54 \$48 \$02 \$02 \$03"
- Standard Hex (no denotation) = A5 01 04 05 54 48 02 02 03
- Crestron Hex Format = \xA5\x01\x04\x05\x54\x48\x02\x02\x03
- RTI = Select port, Hex mode, enter A5 01 04 05 54 48 02 02 03

Go to www.asciitable.com for a handy Decimal/ASCII/Hex conversion chart.

IC Send

Download the [IC Send application](#) from our [crrwww.com](http://www.crrwww.com) home page or Downloads page. This easy-to-use tool can send commands to an IC-HE Head End RS-232 or Ethernet port. As you test your code, the program will come in handy to prove the system is operating properly, or reset things you've changed.

RS-232 Commands

Command	Description	
Power		
Power Off	P0	"\$A5,<dh>,<dl>,2,'P0' " (6 bytes)
Power On	P1	"\$A5,<dh>,<dl>,2,'P1' " (6 bytes)
Power Toggle	PT	"\$A5,<dh>,<dl>,2,'PT' " (6 bytes)
Volume	VL	"\$A5,<dh>,<dl>,3,'VL',<vol level>" (7 bytes) Sets TV volume level 0 = Mute 1 – 63 = Minimum level (1) to maximum volume (63)
RS-232 Control	T0	Not active as yet
Tuning Format	S0=	"\$A5,<dh>,<dl>,3,'S0',<format>" (7 bytes) 0=CATV 1=Off-Air 2=IRC 3=HRC 4=Cable Auto Not always used by modern displays – normally set by TV on-screen menus
Tuning Style	H1=	"\$A5,<dh>,<dl>,3,'H1',<style>" (7 bytes) 1 = 5-digit CableCard style tuning (1-9999) 2 = Virtual HD Major-Minor tuning (tunes to virtual channel ID in display) 3 = Physical HD Major-Minor tuning (physical channel, minor digital)
TC Response	H2=	"\$A5,<dh>,<dl>,3,'H2',<response>" (7 bytes) This pre-sets how the ICC1-232 will respond to TC tuning commands. 0= Ignore, use current settings 1= Analog Only 2= Digital (For CableCard applications only)
Control String	UX	"\$A5,<dh>,<dl>,2+string length,'UX'<string>" (variable bytes) Sends an RS-232 string (ASCII, decimal, or hex) directly to the TV display. Ex: "\$A5,1,2,6,'UX, 'PON', 13" Sends PON, followed by carriage return (device 258)

RS-232 Commands

Command		Description
Channel Up	TU	NA
Channel Dwn	TD	NA
T Channel Prev	TP	NA
Force Channel	TC	“\$A5,<dh>,<dl>,3,'TC', <channel>” (7 bytes) – Tunes to a specific channel 2-127
Select Channel	TT	“\$A5,<dh>,<dl>,2,'TT',<channel>” (7 bytes) – Same as TC
Tune HD	TH	<p>“\$A5,<dh>,<dl>,5,'TH',<H1>,<Major>,<Minor>” (9 bytes) – Digital Tuning</p> <p>Normally, the H1 parameter is 0, allowing the ICC1-232 to use the current H1 tuning format, but it could be used to force a different tuning option. When the display is set to the H1=1 mode, 1-part digital channel, the first byte is (x*256), and the last byte is the value you add to state the channel number. In H1=2 or 3 modes, the bytes represent the Major and Minor channel numbers.</p> <p>Ex:</p> <p>“\$A5,1,4,5,'TH',1,2,3” Device 260, channel 515 (512 +3)</p> <p>“\$A5,1,4,5,'TH',2,2,3” Device 260, virtual channel 2-3</p> <p>“\$A5,1,4,5,'TH',3,2,3” Device 260, physical channel 2, minor 3</p> <p>See Page 5 for instructions on using the TH command to select inputs.</p>
Select Channel	TT	“\$A5,<dh>,<dl>,2,'TT',<channel>” (7 bytes) – Same as TC
Tune Ring	TR	<p>“\$A5,<dh>,<dl>,<ncb>,'TR', [<chan 1>, <chan N>]” (variable bytes)</p> <p>This command stores a Tune Ring, Analog channels only, a series of preset channels accessed by channel up/down commands. This is only for old Smart TVs.</p> <p>Ex1: “\$A5,<dh>,<dl>,6,'TR', 5,4,8,11” sets ring to channels 5, 4, 8 and 11</p> <p>Tip: The ring follows the stored order, channels do not have to be in ascending order</p> <p>Ex2: “\$A5,<dh>,<dl>,8,'TR', \$82,5,\$87,11” sets channels 2-5 and 7-11. You can specify a range using MSB bit for the first channel; the next byte is the last.</p>
Control Lock	LM	<p>“\$A5,<dh>,<dl>,3,'LM',<control>” (7 bytes)</p> <p>0 = Off (unlocked)</p> <p>1 = On (locked)</p> <p>Locks out display commands from an IR remote or front-panel buttons. Feature is not available for all models of displays. Check with CR Tech Support if this function is important to your application.</p>
Sharp Tuning	H9	<p>“\$A5,<dh>,<dl>,3,'H9',<control>” (7 bytes)</p> <p>Used for Sharp control firmware 3.2.</p> <p>H9,1 = Sharp -1 tuning fix (set can't tune a -1 channel, does fine on others)</p> <p>H9,0 = Standard Sharp control</p>
Send IR	LQ=	<p>“\$A5,<dh>,<dl>,3,'LQ',<IR Code>” (7 bytes)</p> <p>Emulates an IR command for special applications:</p> <p>100=Info</p> <p>115=Captions</p> <p>22=Channel Up</p> <p>23=Channel Down</p>

Safety Instructions

Read before operating equipment.

- **Cleaning** - Unplug this product from the wall outlet before cleaning. Do not use liquid cleaners or aerosol cleaners. Use a damp cloth for cleaning.
- **Power Sources** - Use supplied or equivalent UL/CSA approved low voltage DC plug-in transformer.
- **Outdoor Antenna Grounding** - If you connect an outside antenna or cable system to the product, be sure the antenna or cable system is grounded so as to provide some protection against voltage surges and built-up static charges. Section 810 of the National Electrical Code, ANSI/NFPA No. 70, provides information with respect to proper grounding of the mast and supporting structure, grounding of the lead-in wire to an antenna discharge unit, size of grounding conductors, location of antenna discharge unit, connection to grounding electrodes, and requirements for the grounding electrode.
- **Lightning** - Avoid installation or reconfiguration of wiring during lightning activity.

Power Lines - Do not locate an outside antenna system near overhead power lines or other electric light or power circuits or where it can fall into such power lines or circuits. When installing an outside antenna system, refrain from touching such power lines or circuits, as contact with them might be fatal.

- **Overloading** - Do not overload wall outlets and extension cords as this can result in a risk of fire or electric shock.
- **Object and Liquid Entry** - Never push objects of any kind into this product through openings as they may touch dangerous voltage points or short out parts, resulting in a fire or electric shock. Never spill liquid of any kind on the product.
Servicing - Do not attempt to service this product yourself as opening or removing covers may expose you to dangerous voltage or other hazards. Refer all servicing to qualified service personnel.
- **Damage Requiring Service** - Unplug this product from the wall outlet and refer servicing to qualified service personnel under the following conditions:
 - When the power supply cord or plug is damaged.
 - If liquid spills or objects fall into the product.
 - If the product is exposed to rain or water.
 - If the product does not operate normally by following the operating instructions. Adjust only those controls that are covered by the operating instructions. An improper adjustment of other controls may result in damage and will often require extensive work by a qualified technician to restore the product to its normal operation.
 - If the video product is dropped or the cabinet is damaged.
 - When the video product exhibits a distinct change in performance, this indicates a need for service.

* Note to CATV system installer: This reminder is provided to call CATV system installer's attention to Article 820-40 of the National Electrical Code (Section 54 of Canadian Electrical Code, Part I), that provides guidelines for proper grounding and, in particular, specifies that the cable ground shall be connected to the grounding system of the building as close to the point of cable entry as possible.

Limited Warranty and Disclaimer

Warranty: Three (3) year limited warranty on all parts and labor for Contemporary Research manufactured products from the day of purchase by authorized dealer. Manufactured products are warranted against defects in materials and workmanship. If Contemporary Research receives notice of such defects during the warranty period, Contemporary Research will repair or replace, at its option, products that prove to be defective.

Exclusions: The above warranty shall not apply to defects resulting from improper or inadequate maintenance by the customer, customers applied software or interfacing, unauthorized modifications or misuse, mishandling, operation outside the normal environmental specifications for the product, use of the incorrect, modified or extended power supply, or improper site operation and maintenance. *Please note Contemporary Research SSV-DX Display Express PC product carries a six month limited warranty.*