



## ***Model OTPN-3850-SA 3.85GHz Wideband FTTH PON Receiver***



## **Instruction Manual**

Phone: (209) 586-1022  
(800) 545-1022  
FAX: (209) 586-1026  
E-Mail: [salesupport@olsontech.com](mailto:salesupport@olsontech.com)

# Table of Contents

<b>INTRODUCTION</b> .....	3
<b>THEORY OF OPERATION</b> .....	3
<b>BLOCK DIAGRAM</b> .....	4
<b>INSTALLATION / ENVIRONMENTAL CONSIDERATIONS</b> .....	5
<b>OPTICAL CONNECTORS AND CLEANING</b> .....	6
<b>INTERNAL CONTROLS</b> .....	6
<b>EXTERNAL INDICATORS AND CONNECTORS</b> .....	6
<b>SETUP AND OPERATION</b> .....	7
<b>ACCESSORIES AND SYSTEM APPLICATIONS</b> .....	8

## INTRODUCTION

The Olson Technology, Inc. **Model OTPN-3850-SA** provides 50-3,850 MHz bandwidth, allowing it to carry CATV signals from 50-870MHz along with two stacked 950-2,150MHz groups of L-Band signals. The L-Band signals are at a level at least 10dB below the CATV signals.

The optical input contains downstream forward path CATV and L-Band signals at 1550nm, downstream Ethernet data at 1490nm and upstream Ethernet data at 1310nm. The optical output passes the 1310nm and 1490 signals. The 1550nm wavelength goes to a photodiode and is amplified. The optical input level is sensed to trigger an optical alarm when the input light level is less than -10dBm. The input optical level is also used to control a PIN diode attenuator to maintain constant RF level as the optical input level varies from 0dBm to -6dBm. The signal is then amplified and output to a single "F" connector output.

The OTPN-3850-SA Integrated PON Receiver dimensions are 1.05" H x 3.15" W x 4.75" L. Optical connections are via two SC/APC connectors, one for the optical input carrying 1310nm, 1490nm & 1550nm, the second for the optical output carrying the 1310nm and 1490nm optical signals. The unit is powered from +12 to +16 Volts DC at 0.2A maximum. A Green Power LED is lit whenever valid supply voltage is applied. A Red LED is lit only when the 1550nm optical power drops below -10dBm, the minimum usable optical input level. The right side of the unit has a single "F" connector providing a 50-3,850MHz signal.

The OTPN-3850 is designed to give optimum performance at a received CATV optical power (1550nm) of -4dBm although it will give good performance over the full rated optical input range of 0dBm to -6dBm.

## THEORY OF OPERATION

Refer to the Block Diagram for the following discussion. The *Optical In* to the receiver, actually carries three wavelengths. The 1550nm  $\pm 10$ nm wavelength carries the downstream CATV and L-Band signals. This wavelength passes through the FWDM (Filter Wavelength Division Multiplexer) to the optical detector. The 1310nm and 1490nm wavelengths usually carry the Ethernet signals in a Fiber-to-the-Home (FTTH) PON application. They pass through the FWDM to the *Optical Out* port. The 1490nm wavelength usually carries the downstream Ethernet signals and the 1310nm wavelength carries the upstream Ethernet signals.

The 1550nm light that reaches the photodiode (PD) is processed by two different circuits. The first circuit measures the DC average current to determine what optical light level is hitting the photodiode. This is converted to a logarithmic value with a scale factor of 1 Volt per decade. An input level of -10dBm yields -1.0 Volts, 20dBm yields -2.0 Volts, etc. See Figure 3 for details of this output. The photodiode RF output also goes to a low-noise, wide-bandwidth RF amplifier. The output of the first amplifier goes to a wide bandwidth PIN diode attenuator which is controlled by the *Optical Level* signal to keep the RF output constant. For each 1dB drop in the input optical level, the RF attenuation of the PIN diode attenuator is decreased by 2dB, matching the optical-to-RF conversion characteristics of the optical detector. This circuit is optimized to operate over the optical input range from -6dBm to 0dBm. **Note that these power levels ONLY refer to the 1550nm energy in the fiber. Since there are multiple wavelengths on the fiber, a simple optical power meter may be fooled by the 1310nm or 1490nm power that may also be contained in the fiber.** The easiest way to measure only the 1550nm power is to use the optical level function that is built into the OTPN-3850. See Figure 3 for the exact transfer function. The optical level function is calibrated at the factory and rivals the accuracy of most field optical power meters.

# BLOCK DIAGRAM

## Olson Technology OTPN-3850-SA 3.85GHz Wideband FTTH PON Receiver

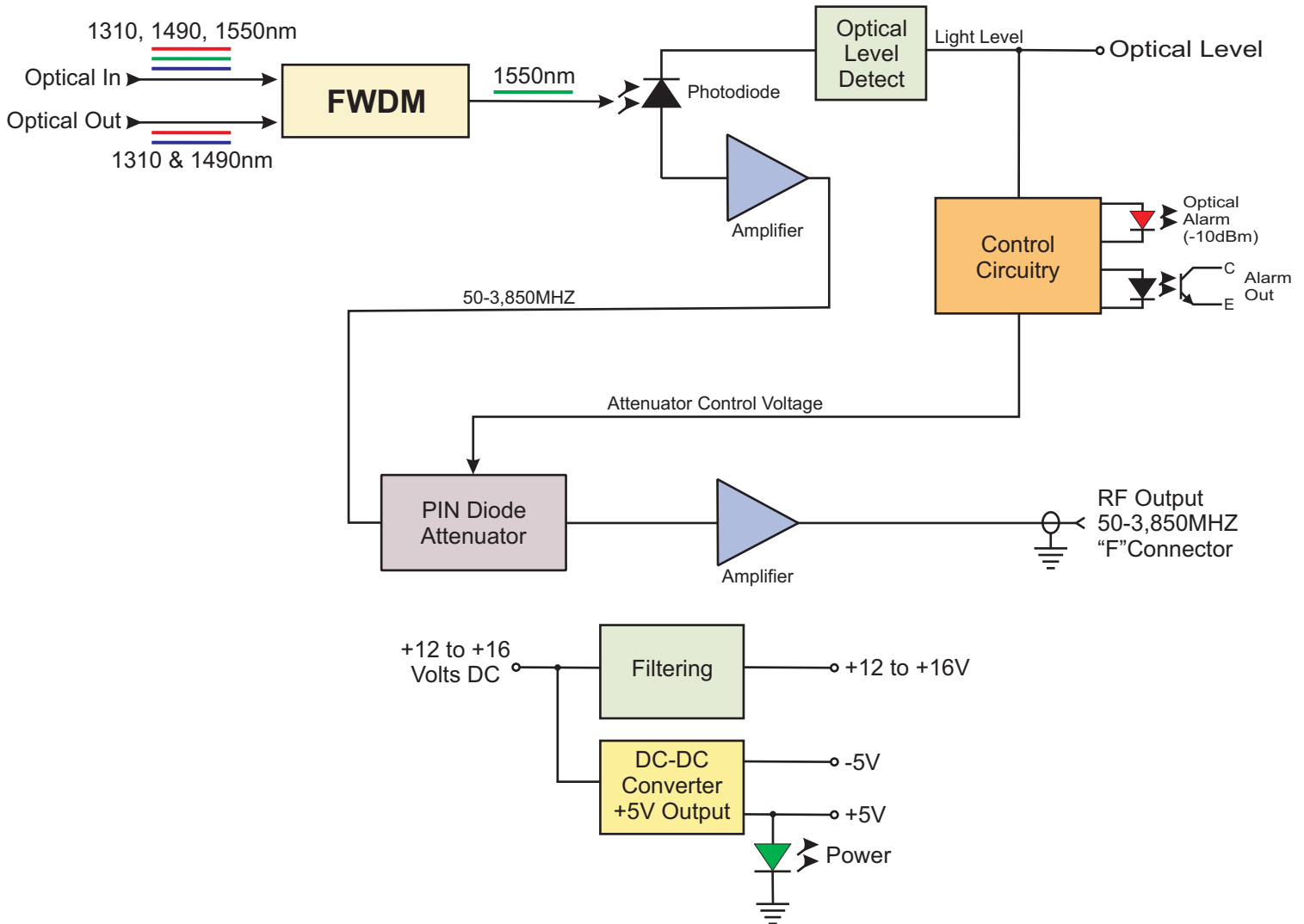

### Notes:

- 1) Bandwidth = 50MHz to 3,850MHz
- 2) Flatness 50-870MHz =  $\pm 1.5\text{dB}$   
950-3,850MHz =  $\pm 2.5\text{dB}$   
Any 20MHz =  $\pm 0.5\text{dB}$
- 3) Output Level = +23dBmV/Ch Typical at 3% OMI/Ch
- 4) AGC Range  $\pm 2\text{dB}$  for Opt. In from 0 dBm to -6dBm
- 5) At -4dBm Optical Input, Min. CATV performance is;  
CNR = 47dB  
CSO = -55dBc  
CTB = -55dBc
- 6) Loss of Light Threshold = -10dBm  $\pm 1\text{dB}$  (1550nm power only)

## INSTALLATION / ENVIRONMENTAL CONSIDERATIONS

The OTPN-3850 receiver is specified to operate from  $-40^{\circ}\text{C}$  to  $+65^{\circ}\text{C}$ . It usually does not require an air-conditioned environment. It should be mounted in an adequately-ventilated area. Like all electronic equipment, it will generally have a longer life span if it is not operated at the extremes of the temperature range. Installation in wet areas or areas of extremely high humidity should be avoided. Extremely dirty or dusty areas should also be avoided if possible.

The OTPN-3850 may be installed and operated in any position on a flat surface. The unit has four slots in the bottom plate to accommodate mounting hardware. If mounting requires a wood screw, use #4 pan-head sheet metal screws. These are commonly available at hardware stores. If mounting with a machine screw (to tapped holes), use 4-40 pan-head screws. Figure 1 shows the dimensions of the bottom plate of the OTPN-3850.

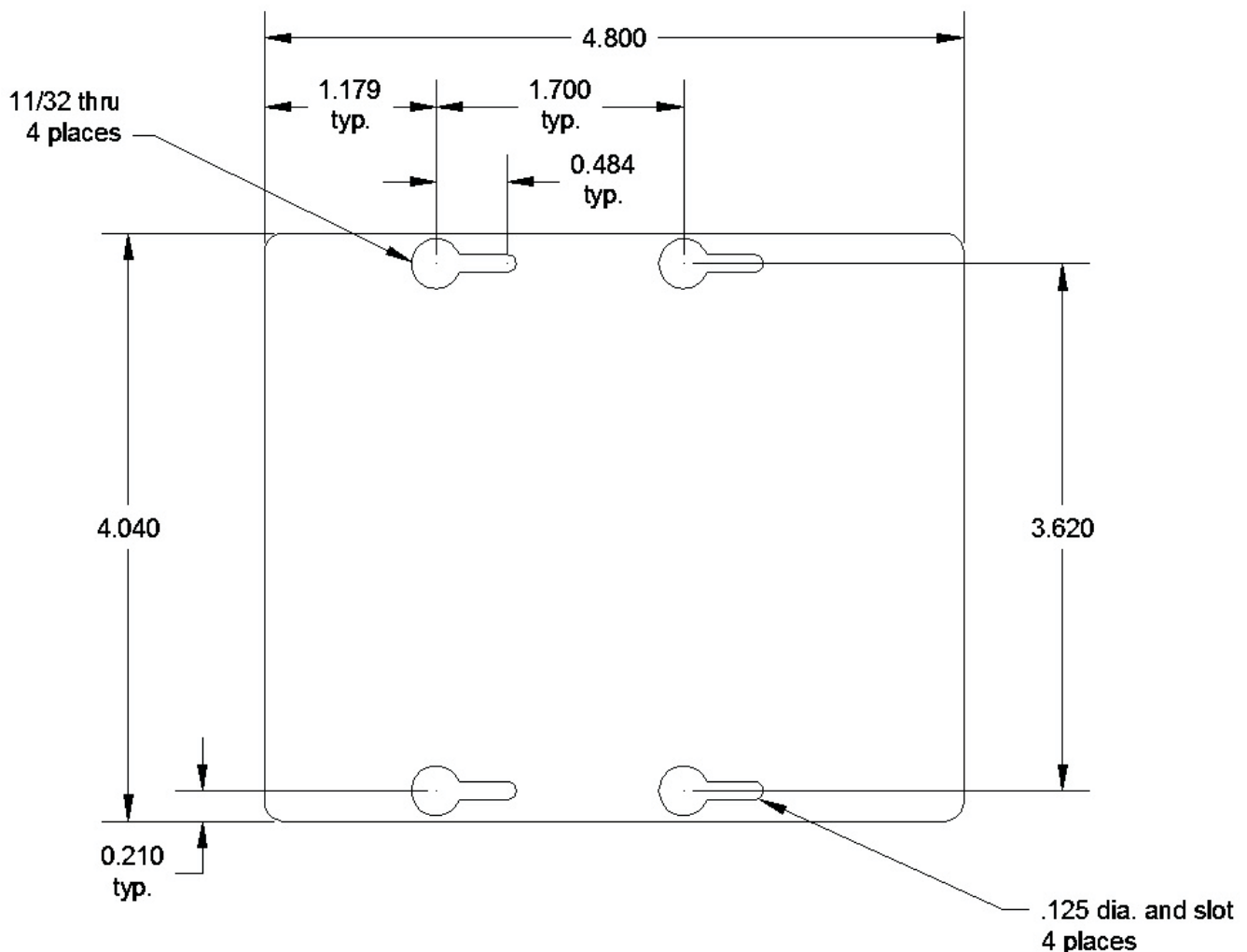

FIGURE 1 - OTPN-3850 MOUNTING PLATE

## OPTICAL CONNECTORS AND CLEANING

The standard optical connectors on the OTPN-3850 are GREEN SC/APC angle-polished connectors. The internal fiber ends can be damaged by the insertion of contaminated connectors. Some types of customer damage to the connectors are not covered under the warranty. Fiber connectors should never be left uncovered. Prepackaged alcohol wipes are the most convenient means of cleaning optical connectors. Clean alcohol and lint free wipes or swabs may also be used.

## INTERNAL CONTROLS

There are no internal user adjustments. There is no reason to open the unit. Any attempt to do so will void the manufacturer's warranty.

## EXTERNAL INDICATORS AND CONNECTORS

There are two external indicator lights and a 10-pin electrical connector. One of the indicators lights green to indicate that power has been applied to the unit. The second red indicator only lights red when the 1550nm optical input power drops below -10dBm.

The 10-pin connector mates to the following connector;

OTPN-3850 Connector: Molex Part Number: 87833-1020  
Mating Connector: Molex Part Number: 51110-1051  
Terminals: Molex Part Number: 50394-8100

The function of the ten (10) pins is shown below;

Pin 1 Alarm Collector (Optically isolated NPN transistor)  
Pin 2 Alarm Emitter (Optically isolated NPN transistor)  
Pin 3 Input Power, +12 to +16 Volts DC  
Pin 4 Ground  
Pin 5 Optical Monitor (Through 1K resistor. See Figure 3.)  
Pin 6 +5 Volts (Through 200 Ohm resistor)  
*Pins 7 through 10 are used to identify the type of module.*  
Pin 7 Not Connected  
Pin 8 Ground  
Pin 9 Not Connected  
Pin 10 Not Connected



**FIGURE 2 - Electrical Connector Pin Configuration**

## SETUP and OPERATION

Mount the unit and apply power. Connect the incoming fiber (*the fiber that carries the 1550nm CATV signal from the headend to the residence*) to the *Optical In* port. Connect the upstream fiber (*the fiber that carries the 1310nm & 1490nm Ethernet signals from the residence to the headend*) to the *Optical Out* port. Connect the *Wideband Output "F"* connector to the equipment that processes the CATV and L-Band signals. Often this may be an L-Band DeStacker. The OTPN-3850 is designed for optimum performance at an optical input of -4dBm (1550nm power only). The easiest way to verify the 1550nm input power is to measure the voltage on pin 5 of the electrical connector (See Figure 2 to locate pin 5). The voltage that is measured on pin 5 can be interpreted in Figure 3. An optical input of -4dBm will yield a voltage of about -0.365 Volts on pin 5. The OTPN-3850 will give acceptable CATV performance for a 1550nm optical input ranging from 0dBm to -6dBm. This corresponds to voltages on pin 5 from +0.115 Volts (0dBm) to -0.585 Volts (-6dBm). This is the preferred method to verify the 1550nm power. An optical power meter can be fooled if there is 1490nm or 1310nm energy on the fiber as well. The *Optical Alarm* LED should be dark and the *Power* LED should be lit green. The system should now be functional.

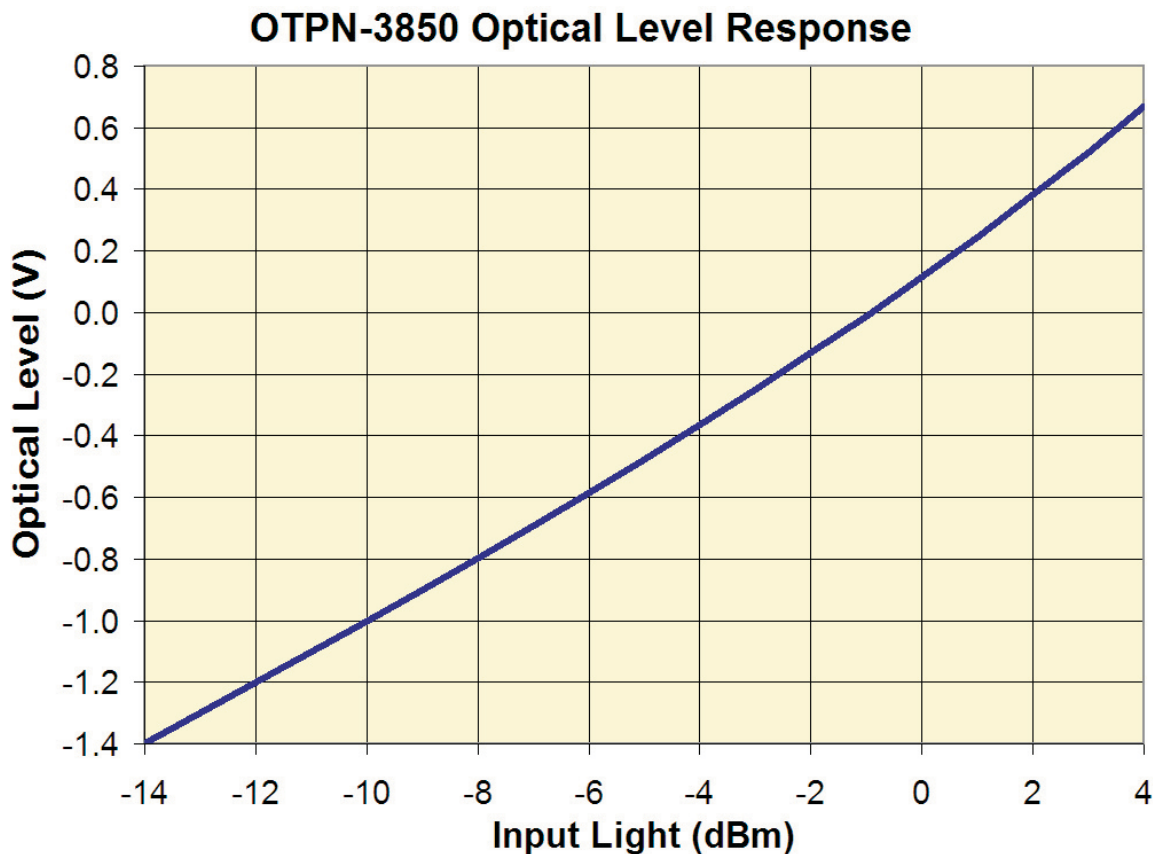

**FIGURE 3 - Electrical Connector Pin Configuration**

## ACCESSORIES AND SYSTEM APPLICATIONS

The OTPN-3850 makes up half of a typical FTTH PON system. The other half is the transmit hardware. Figure 4 shows a typical configuration of a complete FTTH PON system. The two L-Band signals are first stacked and then converted to light separately from the CATV signals. The optical outputs of the CATV and L-Band transmitters are combined by a DWDM Mux and then amplified by an EDFA. The EDFA output is then split a large number of times and a portion of that signal input to numerous OTPN-3850's. The two optical signals from the two transmitters are added together at the photodiode and decoded as a single 50-3,850MHz RF signal. The L-Band DeStacker then separates the two original 950-2,150MHz L-Band signals. Typically the CATV signal is on the same DeStacker output as the *L-Band 1* signal.

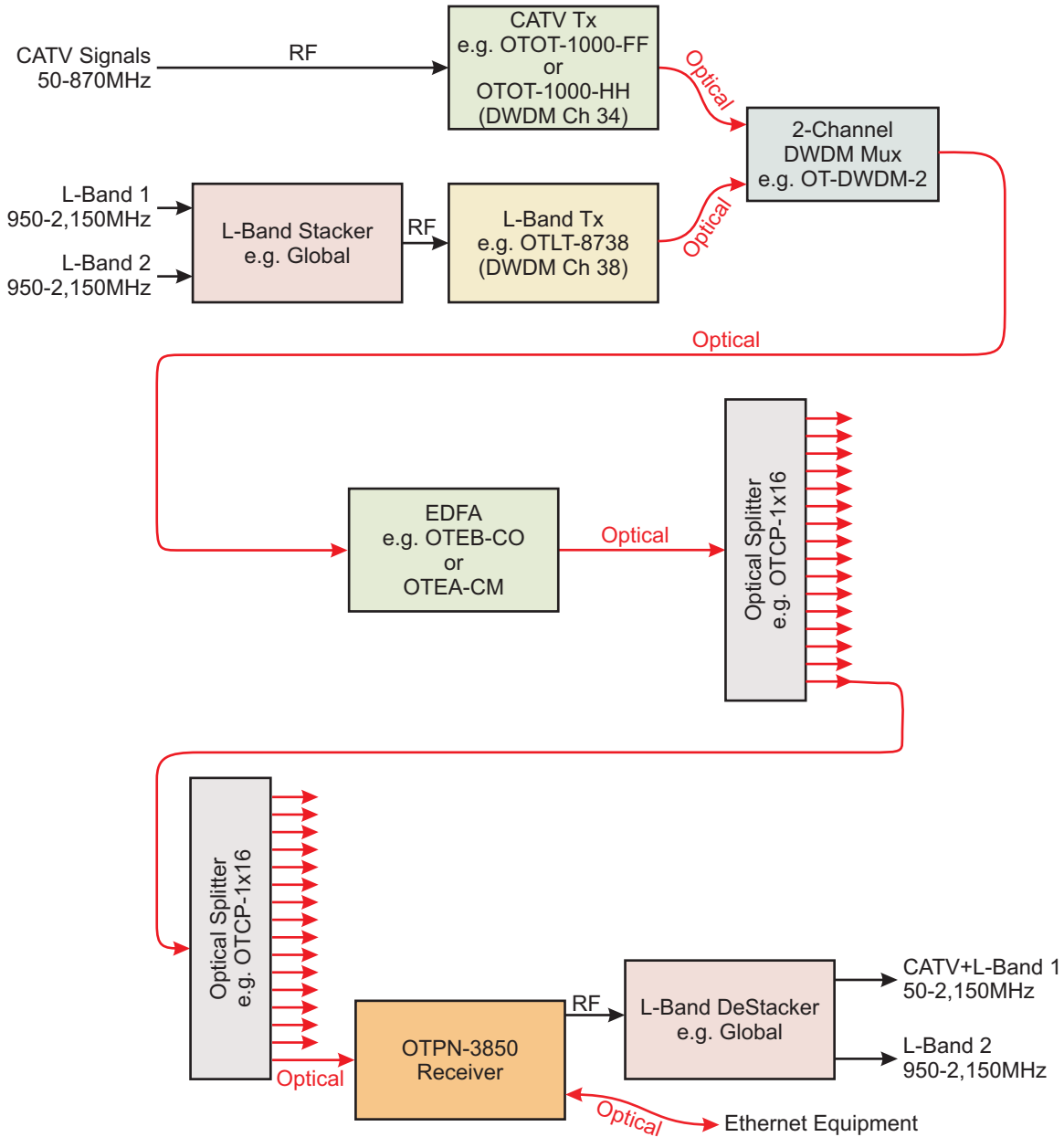

Note: For simplicity, the hardware associated with the Ethernet Signals usually associated with this type of system are not fully shown.

FIGURE 4 - Typical System Application Using the OTPN-3850