

## TIN40R8 ' %&!K Um=bXccf Optical Node

TIN40RD31 is a DOCSIS 3.1 compliant 5-1220 MHz high output two way indoor optical fiber node for CATV, SMATV, FTTx, MDU or private business applications.

The TIN40RD31 has a wide optical input range from 1200 to 1600 nm, making it ideal for either 1310nm or 1550nm systems.

Downstream section has a microprocessor controlled AGC feature which enables variable input optical level while maintaining a constant RF output level.

A high RF output level (37/50dBmV with 13dB tilt) eliminates the need for a separate RF amplifier on the output. A wide -8 to +4dBm optical input level make the node usable in many applications.

The nodes are powered by a plug-in wall type 24VDC power transformer via F-connector.



### Features

- Supports 1220 MHz downstream for DOCSIS 3.1 migration
- High RF output level (37/50dBmV) through GaAs-FET Push Pull technology
- Future proof with field replaceable diplex filters (42/54 Mhz and 85/102 Mhz)
- Extended optical input level range (-8dBm to 4dBm) for maximum flexibility
- Optical automatic gain control (AGC) via built-in microprocessor maintains constant RF output levels over a wide range of optical inputs
- Internal digital optical TX/RX level display enables level monitoring without instrumentation,
- JXP style pad and equalizer control
- 1310 nm, 1550 nm and CWDM DFB laser options for return transmitter
- Superior return transmitter (TX) NPR performance
- Separate -20dB RF test ports for forward and reverse directions
- Powered by a plug-in wall type 24VDC power transformer via F-connector
- Surge protection (6kV) at RF output
- SCTE compliant F type connectors
- Diecast aluminum housing for excellent heat dissipation and RFI shielding

### U

TIN40RD31-1310  
TIN40RD31-1550  
TIN40RD31-(1270)C

DOCSIS 3.1 Compliant 2 Way Optical Node with 1310nm DFB Return Laser  
DOCSIS 3.1 Compliant 2 Way Optical Node with 1550nm DFB Return Laser  
DOCSIS 3.1 Compliant 2 Way Optical Node with 1270nm DFB Return Laser  
Return Laser Note: replace 1270 with CWDM channel needed,  
1270, 1290, 1310, 1330, 1350, 1370, 1390, 1410, 1430, 1450, 1470, 1490,  
1510, 1530, 1550, 1570, 1590, 1610 are the CWDM frequency options

## TIN40R8 ' %&!K Um=bXccf Optical Node

### Forward (Down-Stream)

#### Optical Features (RX)

Optical Input Wavelength	1200...1600 nm
Optical AGC Input Range	-8...+4 dBm (with AGC)
Optical Input Level Test Point	-8...+4 dBm (shown on digital display)
Optical Input Level Indicator	Green LED (> -8 dBm)

#### RF Features

Forward Bandwidth Options	54 - 1220 MHz / 105-1218 MHz (field replaceable plug-in diplex filters)
Gain Tilt	0...3 dB
Flatness	+/- 1.5 dB
Return Loss	Typ. -16 dB (Max. -14)
Test Point	- 20 dB
<b>Link Performance (-1 dBm optical input power, NTSC77 channel, OMI=%3,5)</b>	
Output Level	37/50 dBuV (tilted)
CNR	-51 dBc
CTB	-63 dBc
CSO	-60 dBc

### Return (Up-Stream)

#### Optical Features (TX)

Transmitted Wavelength (TX Laser)	1310 nm, 1550 nm DFB, ITU CWDM (1270 nm...1610 nm) DFB
Optical Output Power	2 mW (3 dBm)
Optical Output Level Indicator	-0,25 mW (shown on digital display)

#### RF Features

Reverse Bandwidth Options	5 - 42 MHz/ 5-85 MHz (field replaceable)
Input Level Control	20..0 dB (with plug-in JXP controllers)
Test Point	- 20 dB
Recommended RF Input	20 dBmV ± 10 dB
Return Loss	-16 dB

#### Link Performance (6dB link loss, 10 km fiber + optical attenuator)

Optimum Total Input Level	18 dBmV
NPR Peak / Input Level	53/21 dB / dBmV tot
TX Input Level (@ NPR=-41dB)	8-21 dBmV tot
TX Input Level (@ NPR=-38dB)	5-21 dBmV tot

### General Features

Connectors	1 F type RF In/Out and 1 F Type Test Reverse 1 SC/APC Optical In and 1 SC/APC Optical Out
Surge Protection	IEEEC62.41 Cat.A3 (6kV,200A)
Powering	11-36 VDC with wall type external power supply
Power Consumption	8 Watt
Operating Environment Temperature	-30...+55 C°
Housing	IP54 class protection, diecast housing
Weight	1,7 /3.7 (kg / lb)
Dimension	19,5 x 13,6 x 7,5 / 7-5/8 x 5-3/8 x 3 (cm / inch)

# TIN40R8 ' %&!K Um=bXccf`Optical Node

## Block Diagram

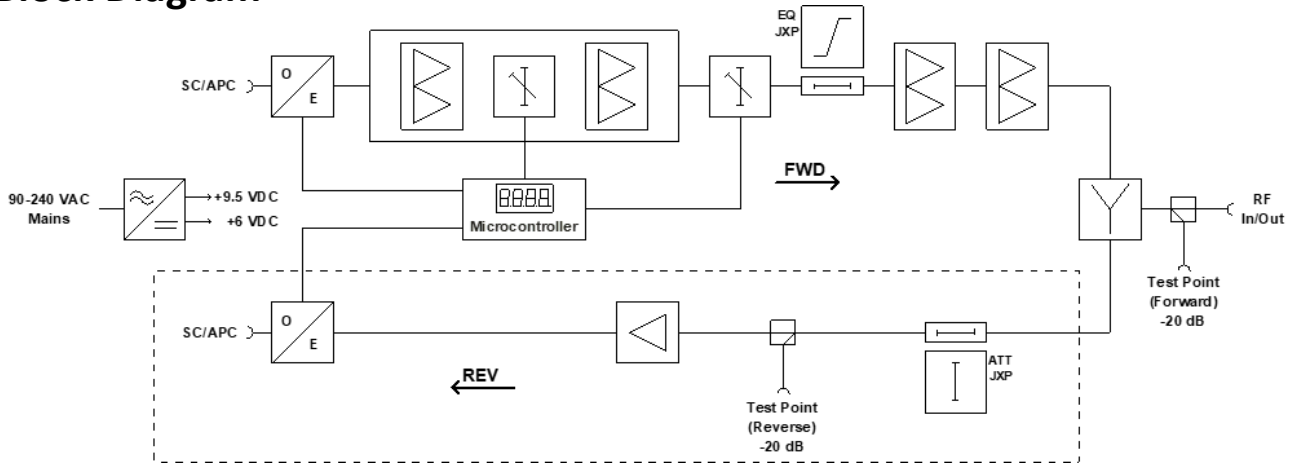

## DFB Noise Power Ratio (NPR) Curve

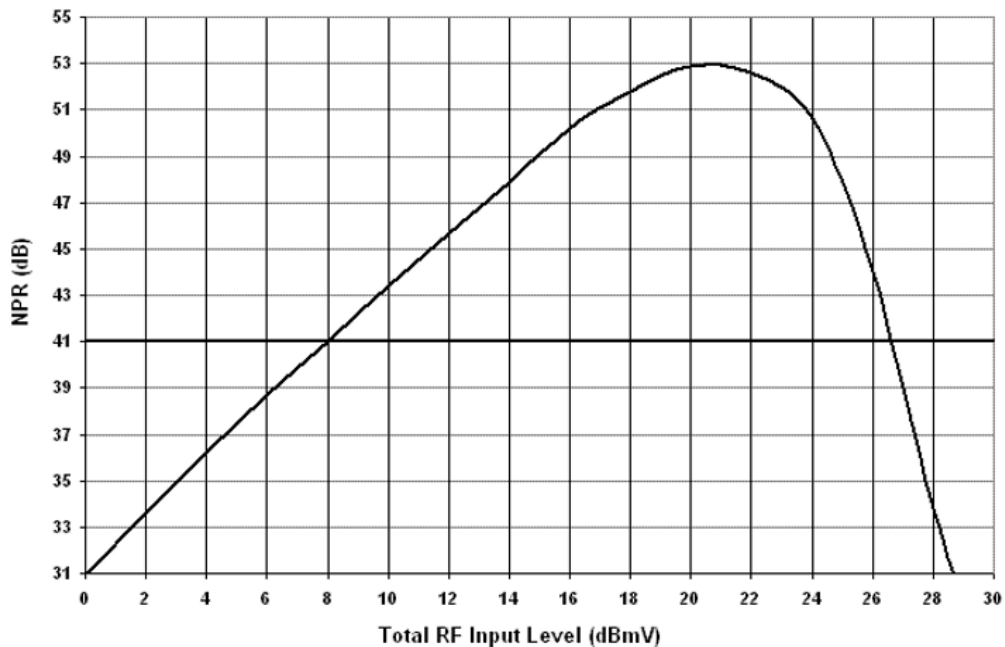

# TIN40R8 ' %&!K Um=bXccf`Optical Node

## Interior Design and Connections

